

G700B

Vlindertuin

Le jardin des papillons

Butterfly garden

Schmetterlingsgarten

Jardin de mariposas

Giardino delle Farfalla

Montagehandleiding

Notice de montage

Assembling manual

Montageanleitung

Instrucciones para el montaje

Istruzioni di installazione

Leeftijd
Age group
Age / Alter
Edad / Età
1 - 3

EUROPLAY nv
Eegene 9
B-9200 DENDERMONDE
tel. 32.52.22 66 22
fax.32.52.22 67 22
www.europlay.eu

Dat.: 22/04/2021

Rev.: -

Page: 1/5

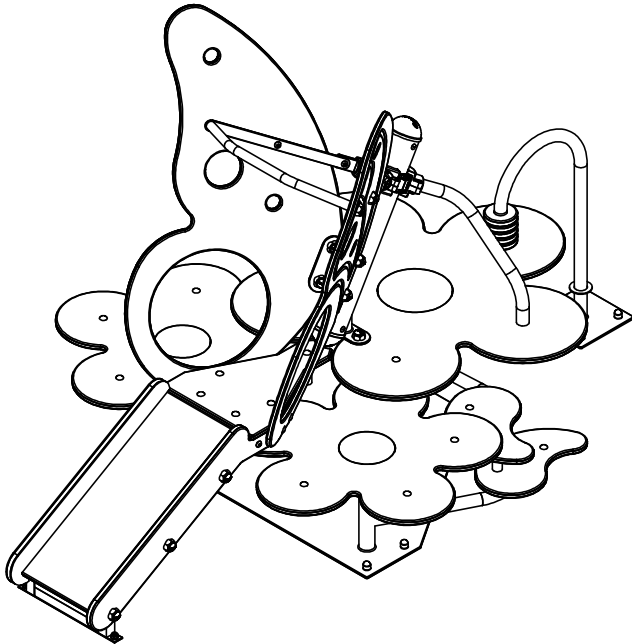

115kg

VALHOOGTE / HAUTEUR DE CHUTE /
FALL HEIGHT / FALLHÖHE/
ALTURA DE CAÍDA / ALTEZZA DI CADUTA

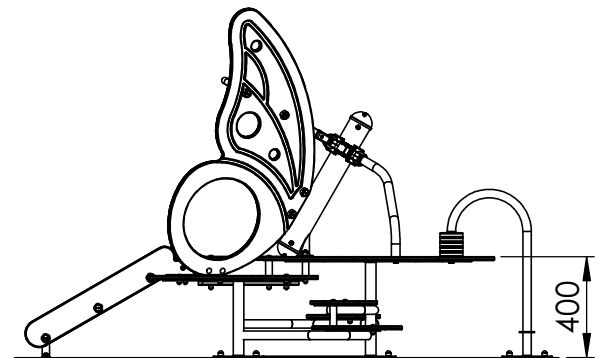

Groundlevel

VEILIGHEIDSAFSTAND / ESPACE DE CHUTE / SAFETY AREA /
SICHERHEITSAFSTAND / ZONA DE SEGURIDAD / DISTANZA DI SICUREZZA

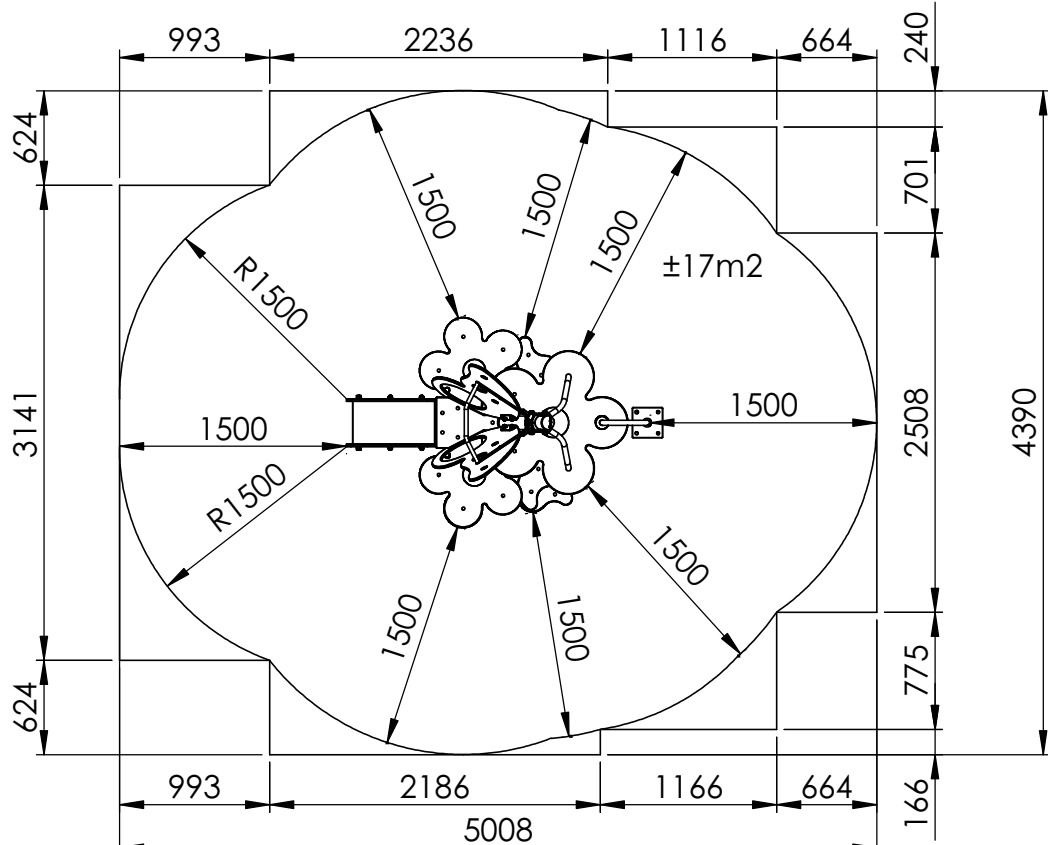



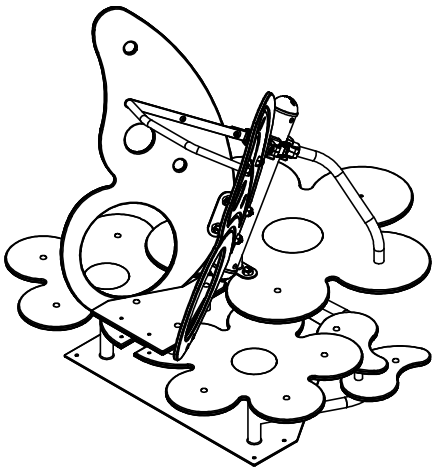
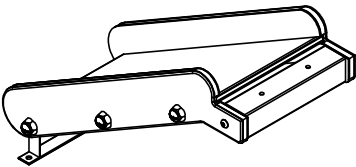
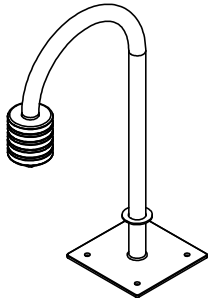

AFMETINGEN
DIMENSIONS
MASSE
DIMENSIONES
DIMENSIONI
L: 2,1m
Br: 1,4m
H: 1,4m

±19 m2

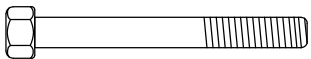
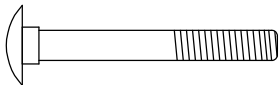
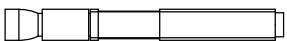
Benodigdheden - Liste des pièces - Materials - Benötigtes - Accesorios - Requisiti

1x G700-As-Vlinder-02	1x G700-As-Loopwand-01	1x G700-As-Glijbuis-02
		
1362x1390x1385 100.62kg	673x360x440 9.35kg	417x200x668 4.29kg

1x M10x40	
2x M8x105	
12x M10x95	
12x M10	
2x M8	
12x M10	
12x M10	
2x M8	

①

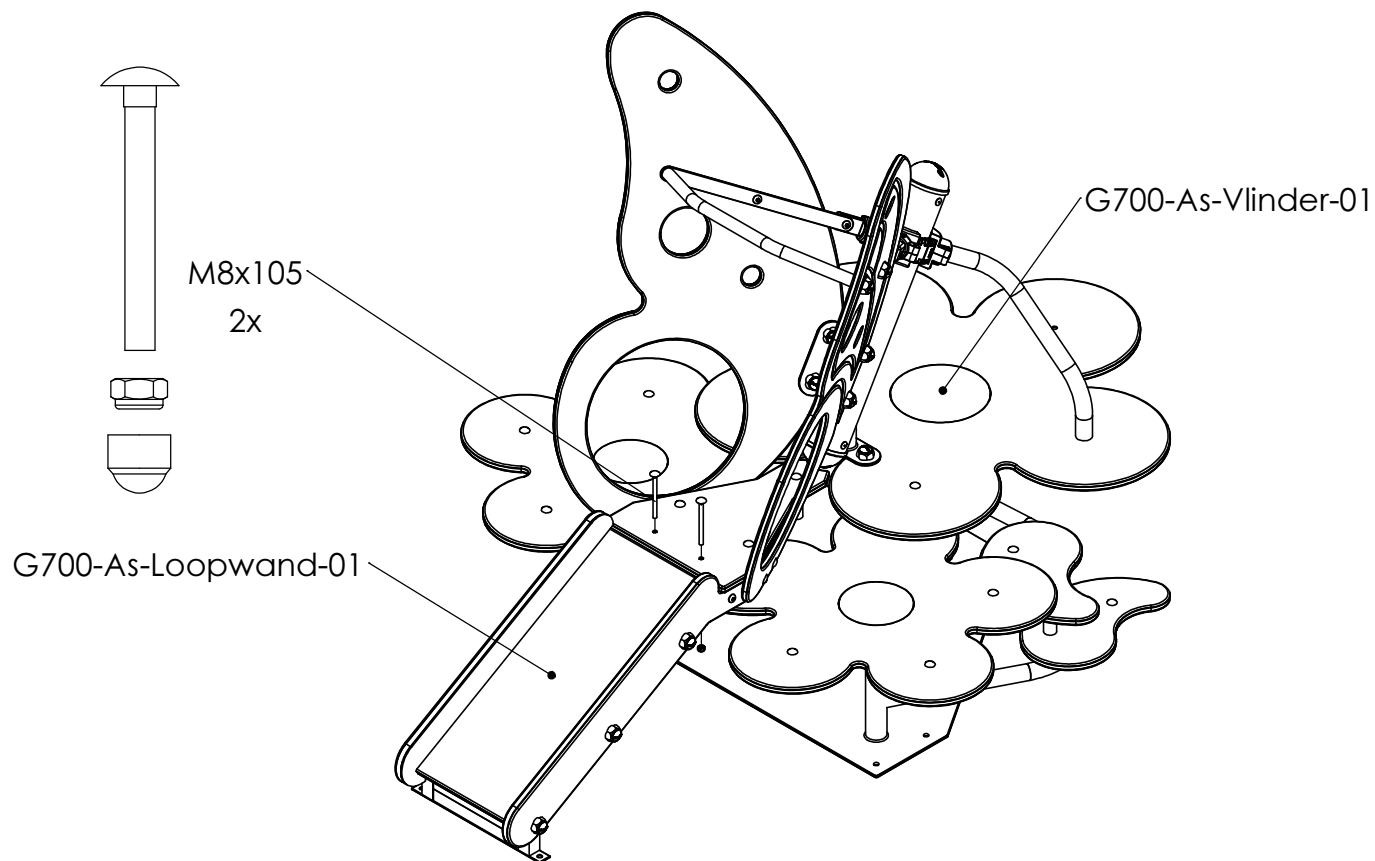

②

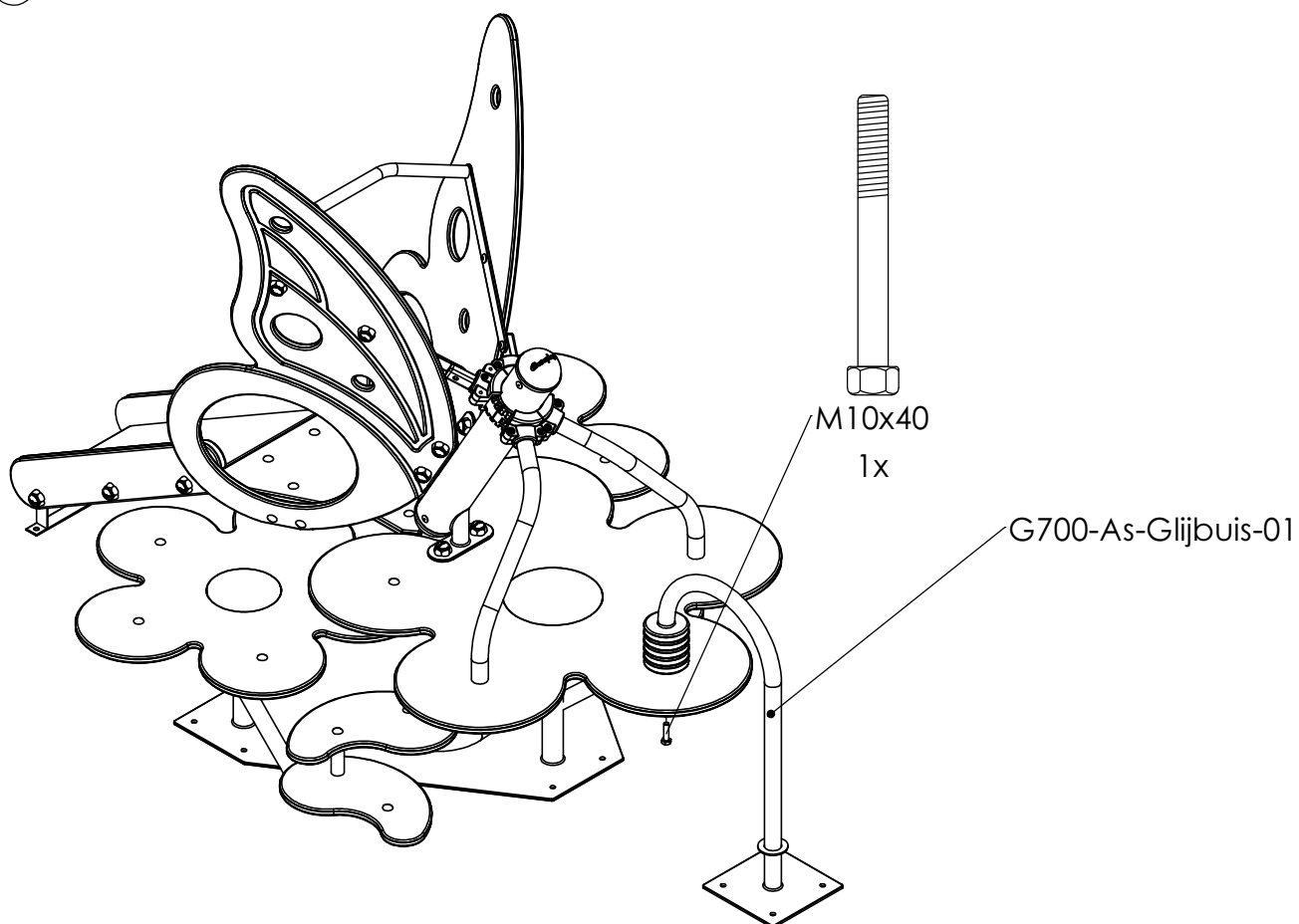

3

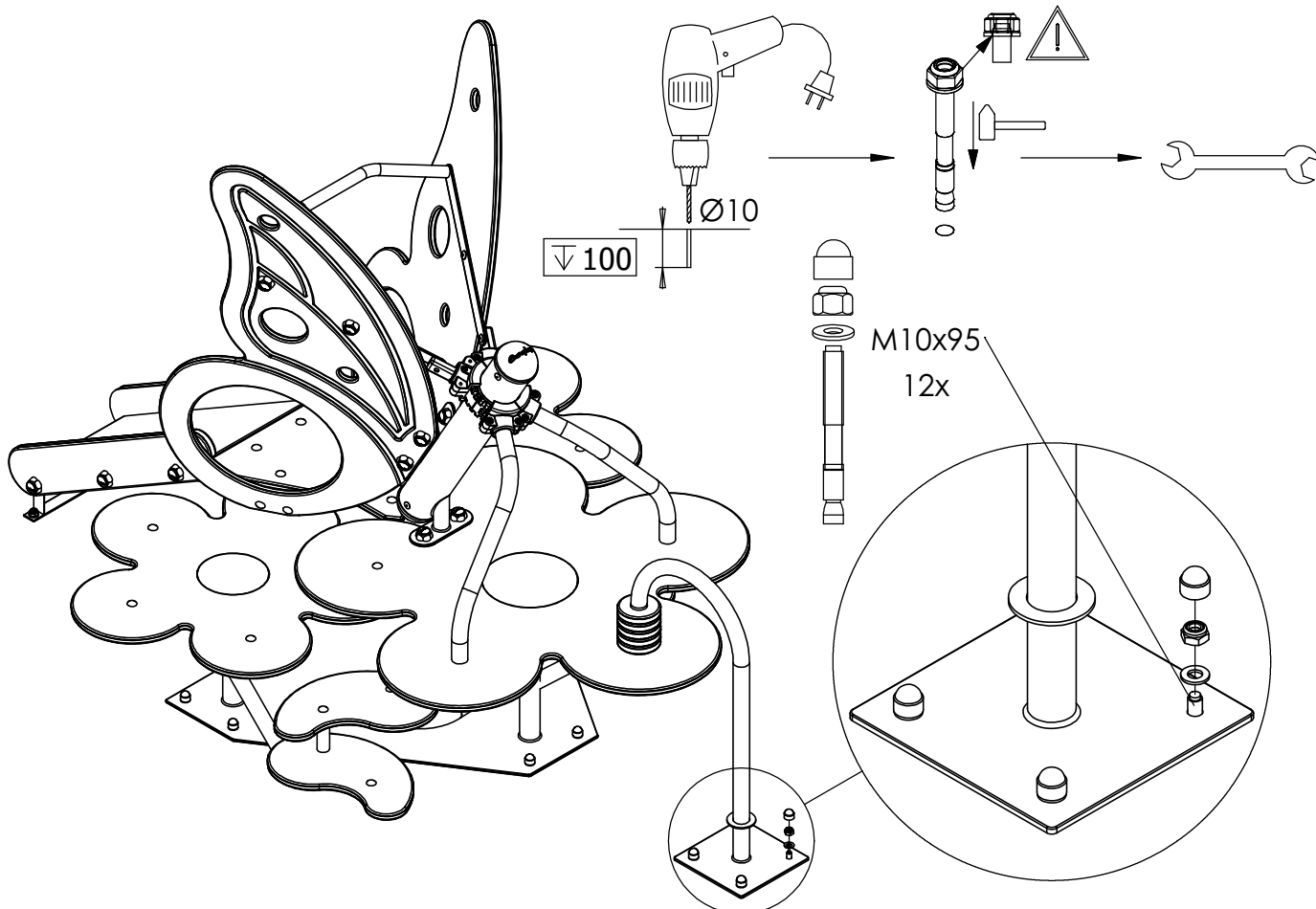
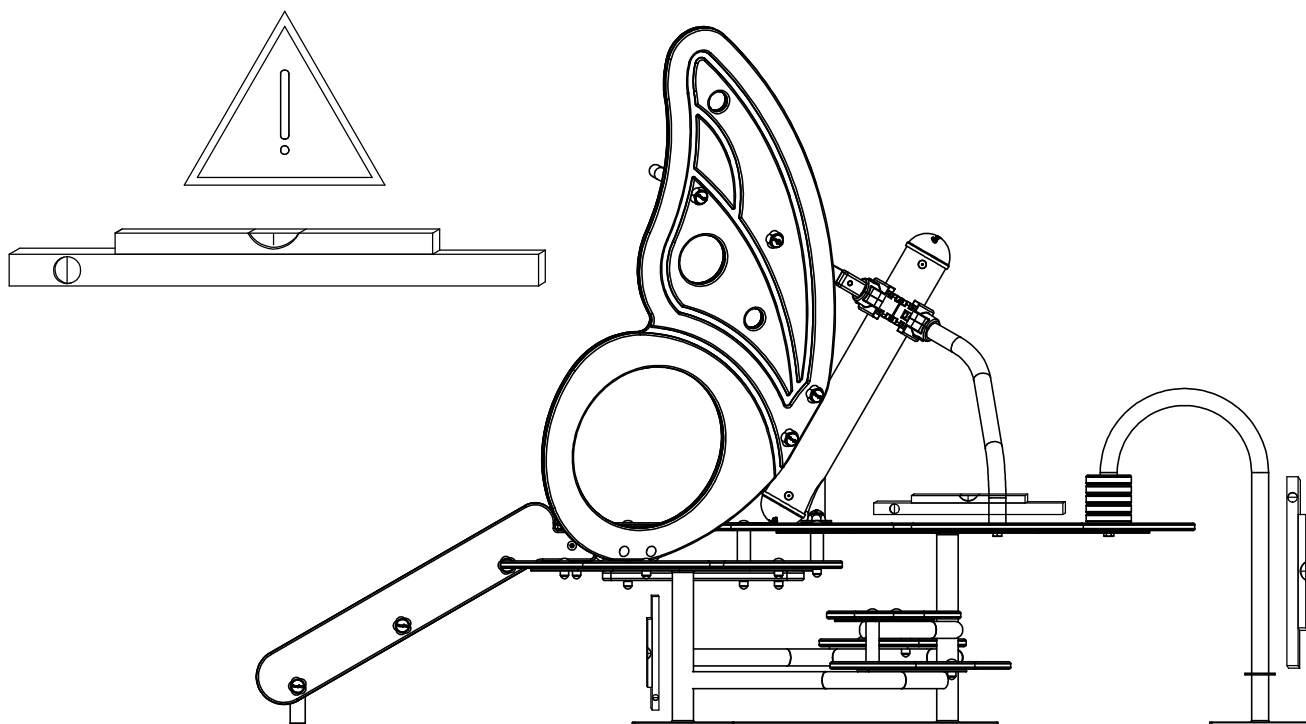

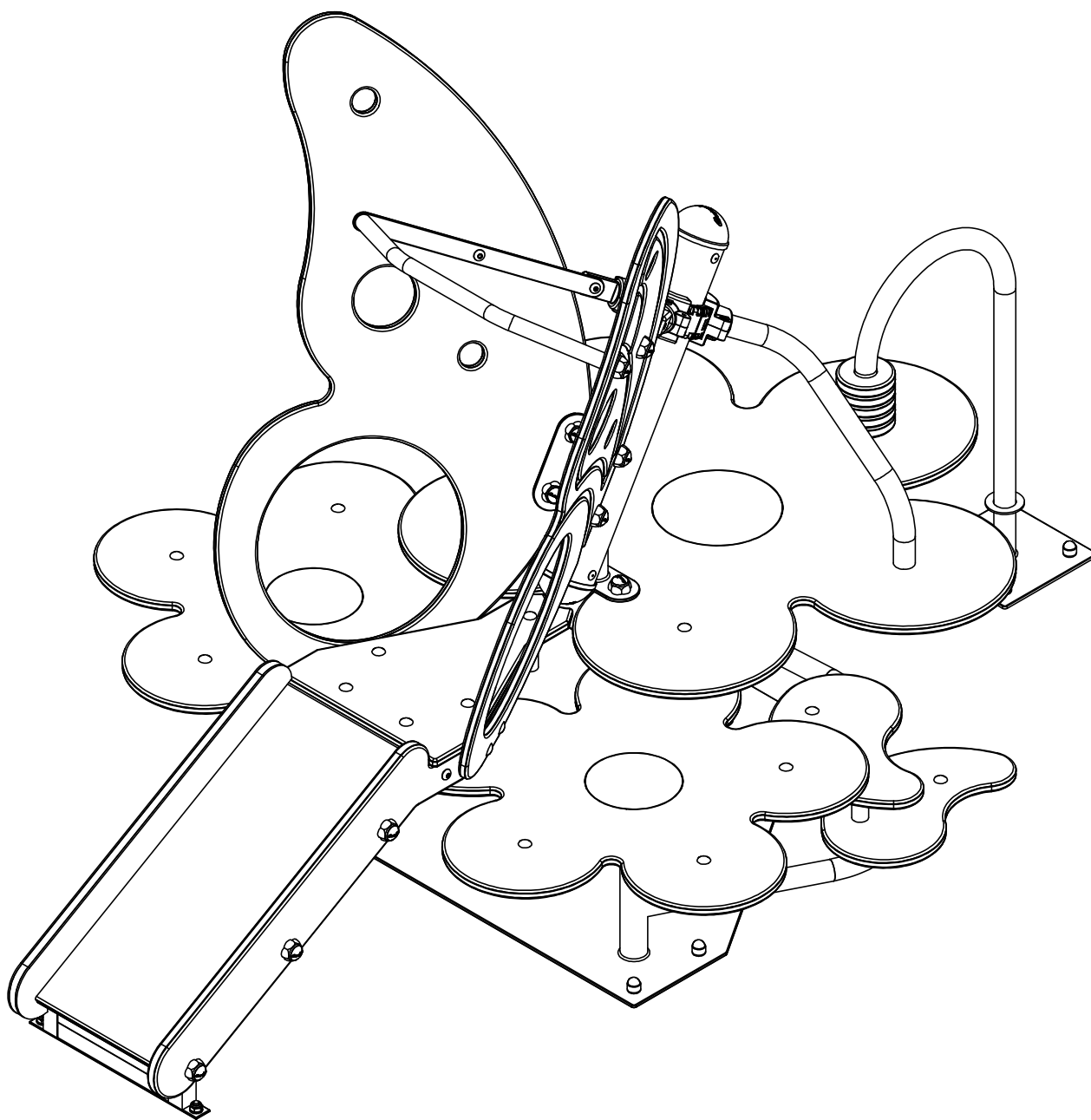

④

Bij droog weer moeten alle bouten en schroeven opnieuw aangespannen worden.
Par temps sec il faut resserrer régulièrement toute la visserie.
By dry and warm weather check the tightness of all bolts and screws.
Bei trockenem Wetter müssen alle Schrauben und Bolzen aufs neue angespannt werden.
Para el tiempo seco, se necesita cerrar o ajustar los tornillos y tuercas.
Con tempo asciutto, tutti i bulloni e le viti devono essere avvitate nuovamente.