

# 8200

HAAS  
LAPIN  
HASE  
RABBIT  
LIEBRE  
LEPRE

## Montagehandleiding Notice de montage Assembling manual Montageanleitung Instrucciones para el montaje Istruzioni di installazione

Leeftijd  
Age group  
Age / Alter  
Edad / Età  
2 - 6

EUROPLAY nv  
Eegene 9  
B-9200 DENDERMONDE  
tel. 32.52.22 66 22  
fax.32.52.22 67 22  
www.europlay.eu

Dat.: 27/05/2019  
Rev.: -  
Page: 1/4

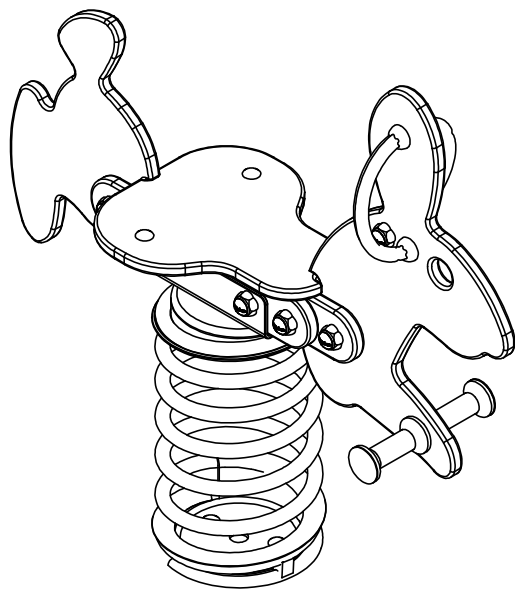

45kg

VALHOOGTE / HAUTEUR DE CHUTE /  
FALL HEIGHT / FALLHÖHE/  
ALTURA DE CAÍDA / ALTEZZA DI CADUTA

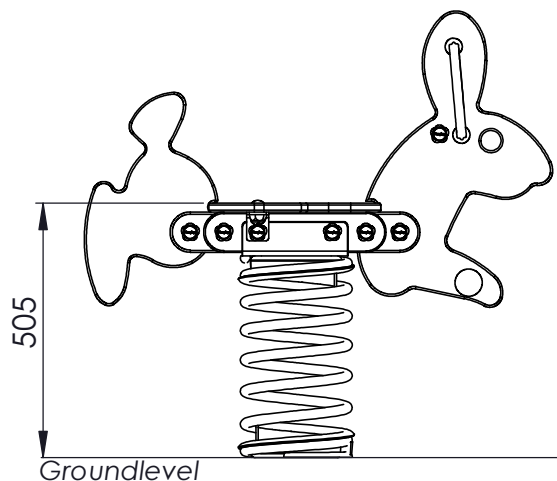

VEILIGHEIDSAFSTAND / ESPACE DE CHUTE / SAFETY AREA /  
SICHERHEITSAFSTAND / ZONA DE SEGURIDAD / DISTANZA DI SICUREZZA

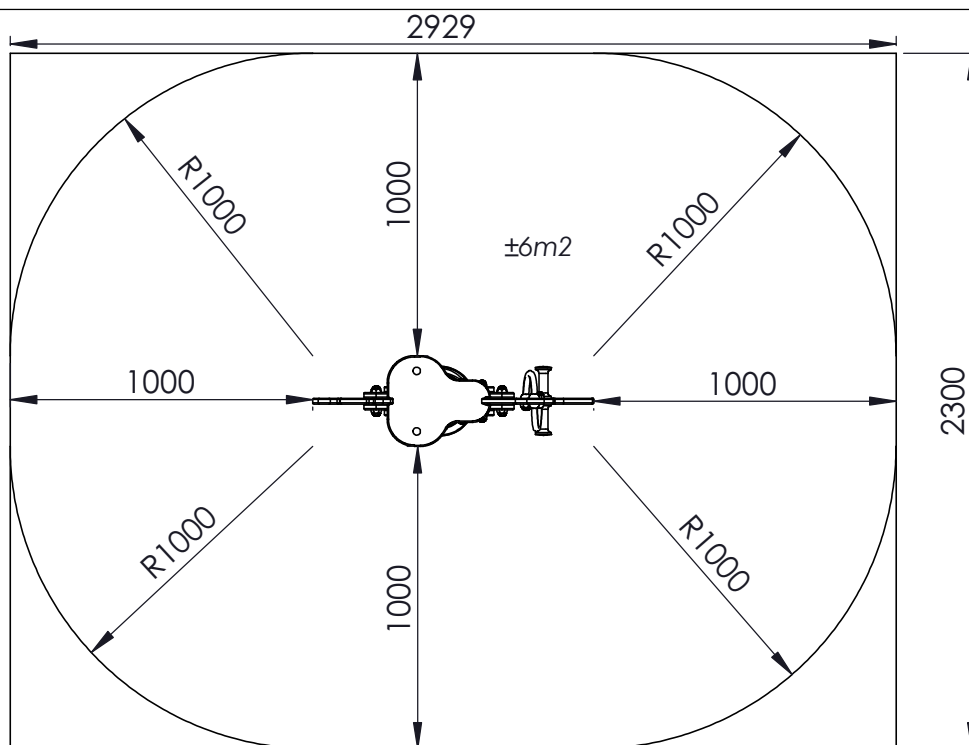

AFMETINGEN  
DIMENSIONS  
MASSE  
DIMENSIONES  
DIMENSIONI  
L: 1m  
Br: 0,3m  
H: 0,9m



Valdempend materiaal noodzakelijk  
Sol amortissant obligatoire  
Shock-absorbing underground required  
Fallschutz erforderlich  
Suelo amortiguante obligatorio  
Materiale di fondo antitrauma obbligatorio

±7m2

## Benodigdheden - Liste des pièces - Materials - Benötigtes - Accesorios - Requisiti

1x 8200-As-Lijf-01

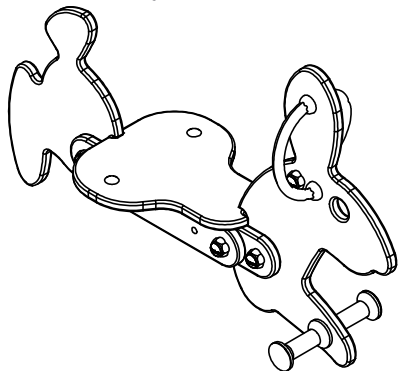

929x588x225

7,89kg

1x Lb-As-Veer-01

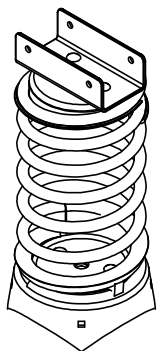

Ø225x556

21,53kg

4x Lb-M-Veervoet-03

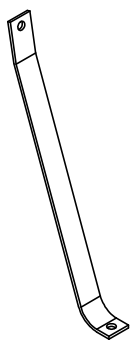

208x203x40

0,8kg

1x Lb-M-Veervoet-02

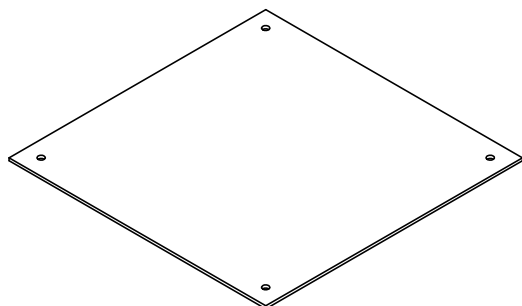

480x480x5

8,86kg

4x M10x25

1x M10x125

1x M10x135



4x M10x30

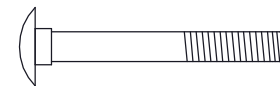

6x M10



4x M10



8x M10



8x M10



4x White



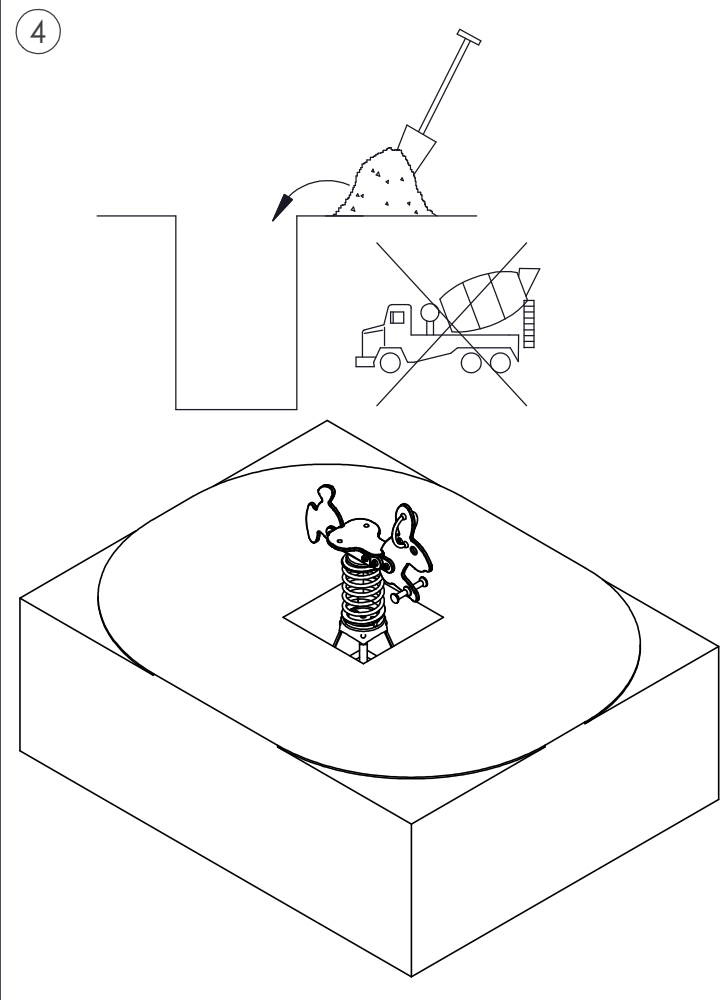
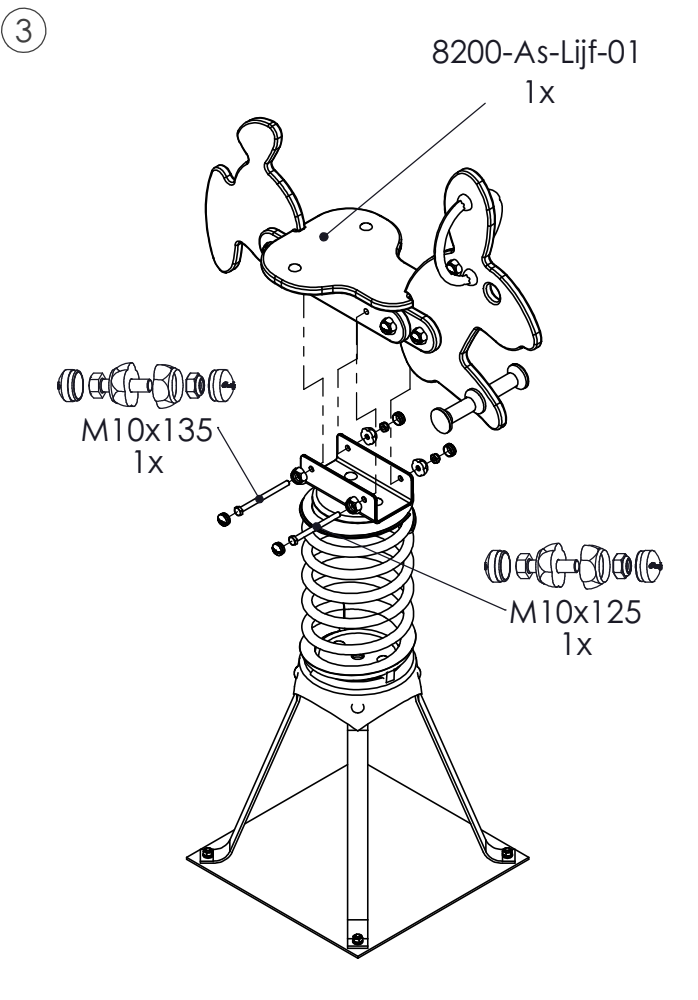
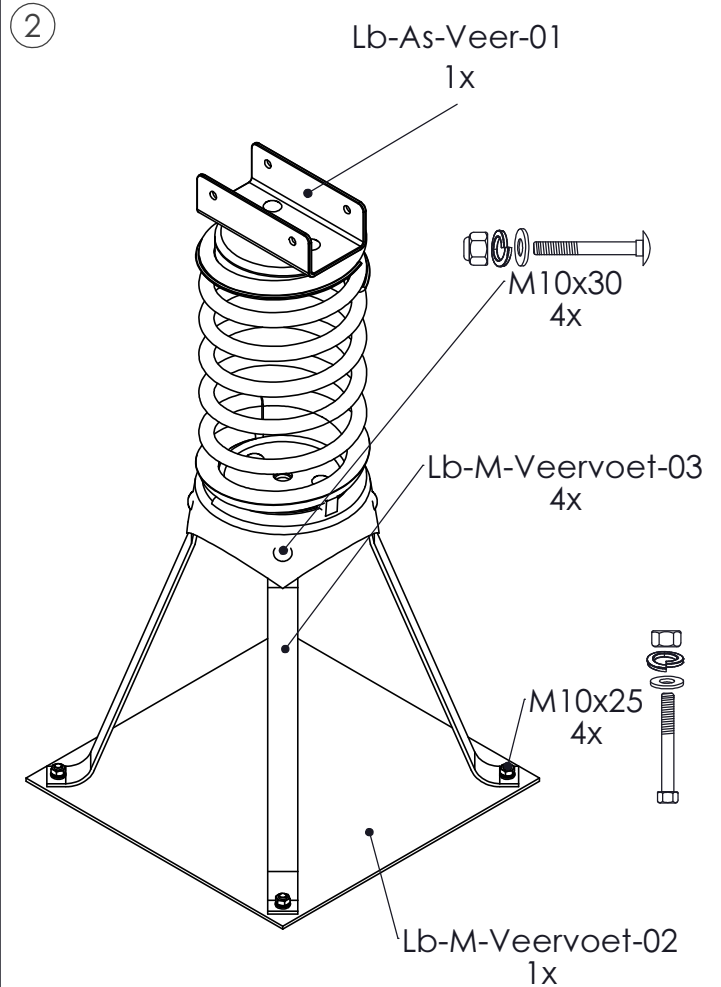
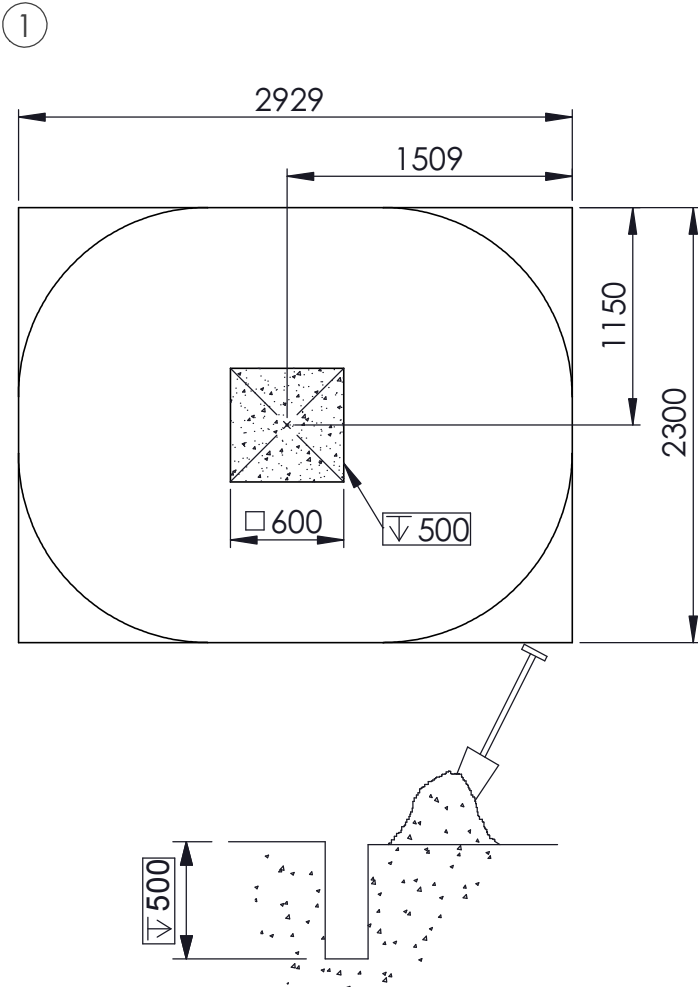

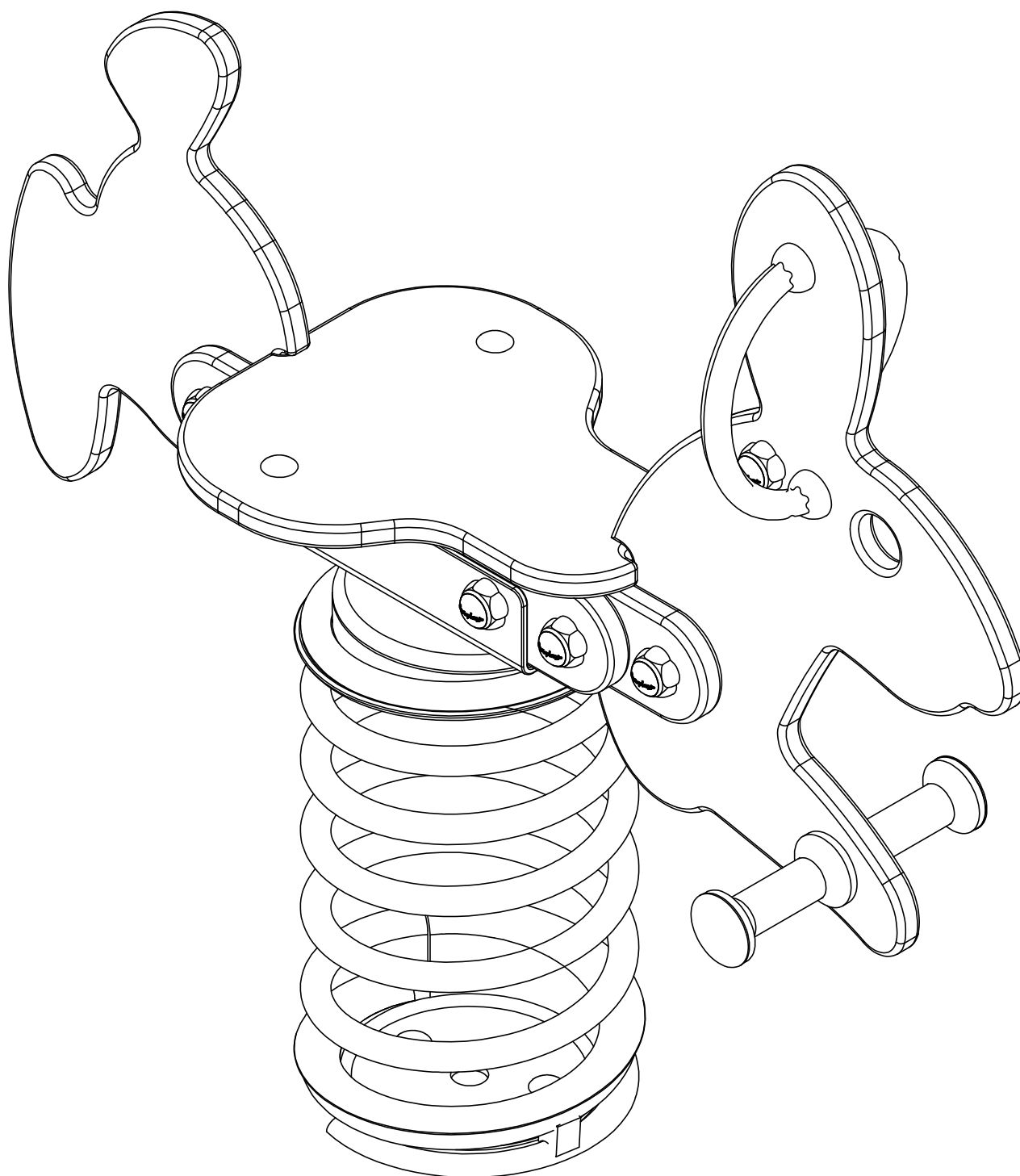

- ⑤ Bij droog weer moeten alle bouten en schroeven opnieuw aangespannen worden.  
Par temps sec il faut resserrer régulièrement toute la visserie.  
By dry and warm weather check the tightness of all bolts and screws.  
Bei trockenem Wetter müssen alle Schrauben und Bolzen aufs neue angespannt werden.  
Para el tiempo seco, se necesita cerrar o ajustar los tornillos y tuercas.  
Con tempo asciutto, tutti i bulloni e le viti devono essere avvitati nuovamente.