

F700B

Peter Pan
Peter Pan
Peter Pan
Peter Pan
Peter Pan
Peter Pan

Montagehandleiding Notice de montage Assembling manual Montageanleitung Instrucciones para el montaje Istruzioni di installazione

Leeftijd
Age group
Age / Alter
Edad / Età
2 - 6

EUROPLAY nv
Eegene 9
B-9200 DENDERMONDE
tel. 32.52.22 66 22
fax.32.52.22 67 22
www.europlay.eu

Dat.: 16/12/2019
Rev.: -
Page: 1/7

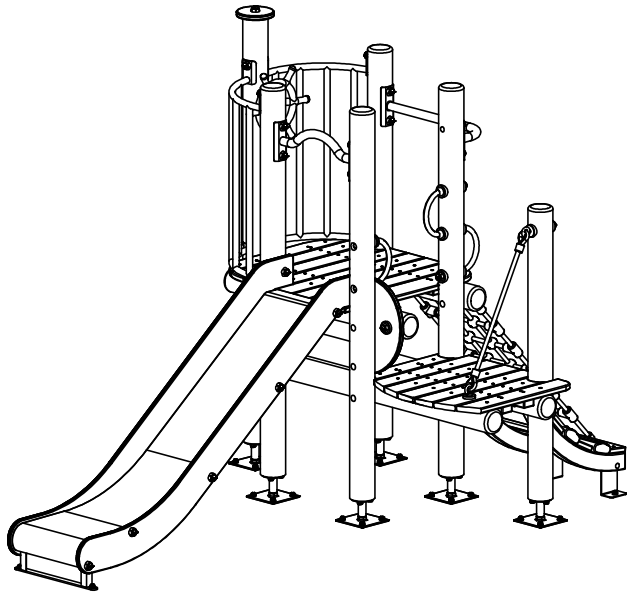

128,87kg

VALHOOGTE / HAUTEUR DE CHUTE /
FALL HEIGHT / FALLHÖHE/
ALTURA DE CAÍDA / ALTEZZA DI CADUTA

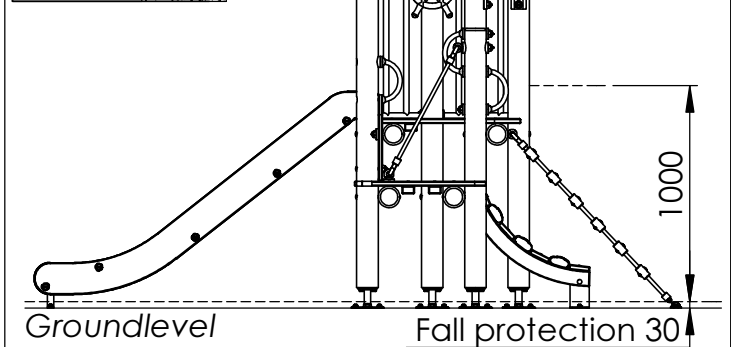
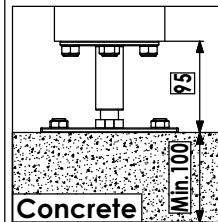

VEILIGHEIDSAFSTAND / ESPACE DE CHUTE / SAFETY AREA /
SICHERHEITSAFSTAND / ZONA DE SEGURIDAD / DISTANZA DI SICUREZZA

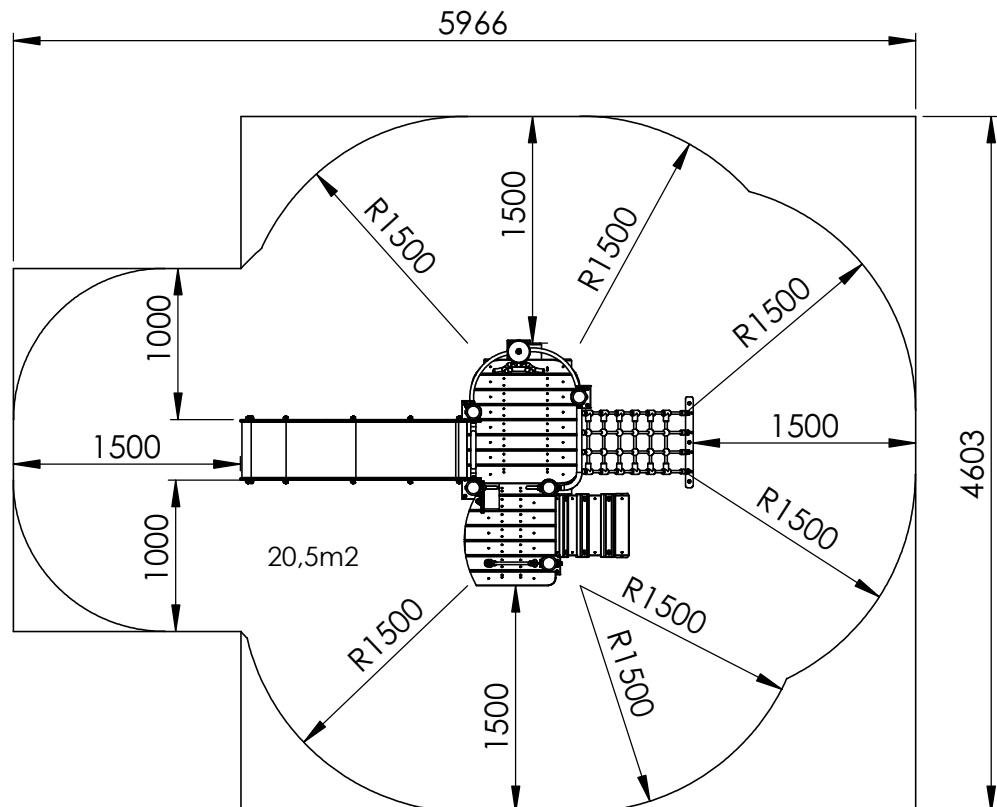

AFMETINGEN
DIMENSIONS
MASSE
DIMENSIONES
DIMENSIONI
L: 3.0m
Br: 1.6m
H: 1.8m

24,5m²





F700B

Montagehandleiding - Notice de montage
 Assembling manual - Instrucciones para el montaje
 Montageanleitung - Istruzioni di installazione

Dat.: 16/12/2019

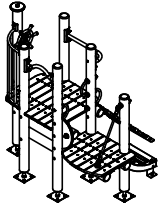
Page: 2/7

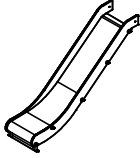
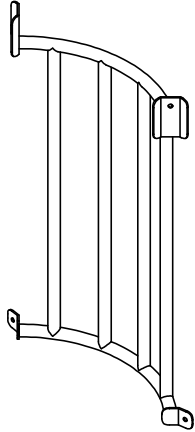
Benodigdheden - Liste des pièces - Materials - Benötigtes - Accesorios - Requisiti

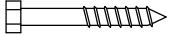
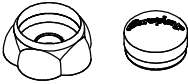
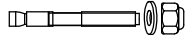
 <p>F700B BASIC</p> 	 <p>G490B</p> 	<p>1x F700-M-Balstrde-01</p>  <p>795,2 x 600 x 313 4.59kg</p>
<p>4x M8</p> 	<p>4x M8x50</p> 	
<p>4x White</p> 	<p>31x M10X95</p> 	

01

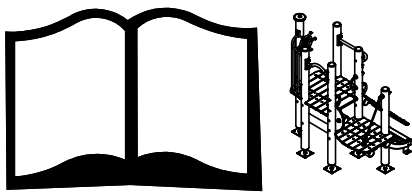
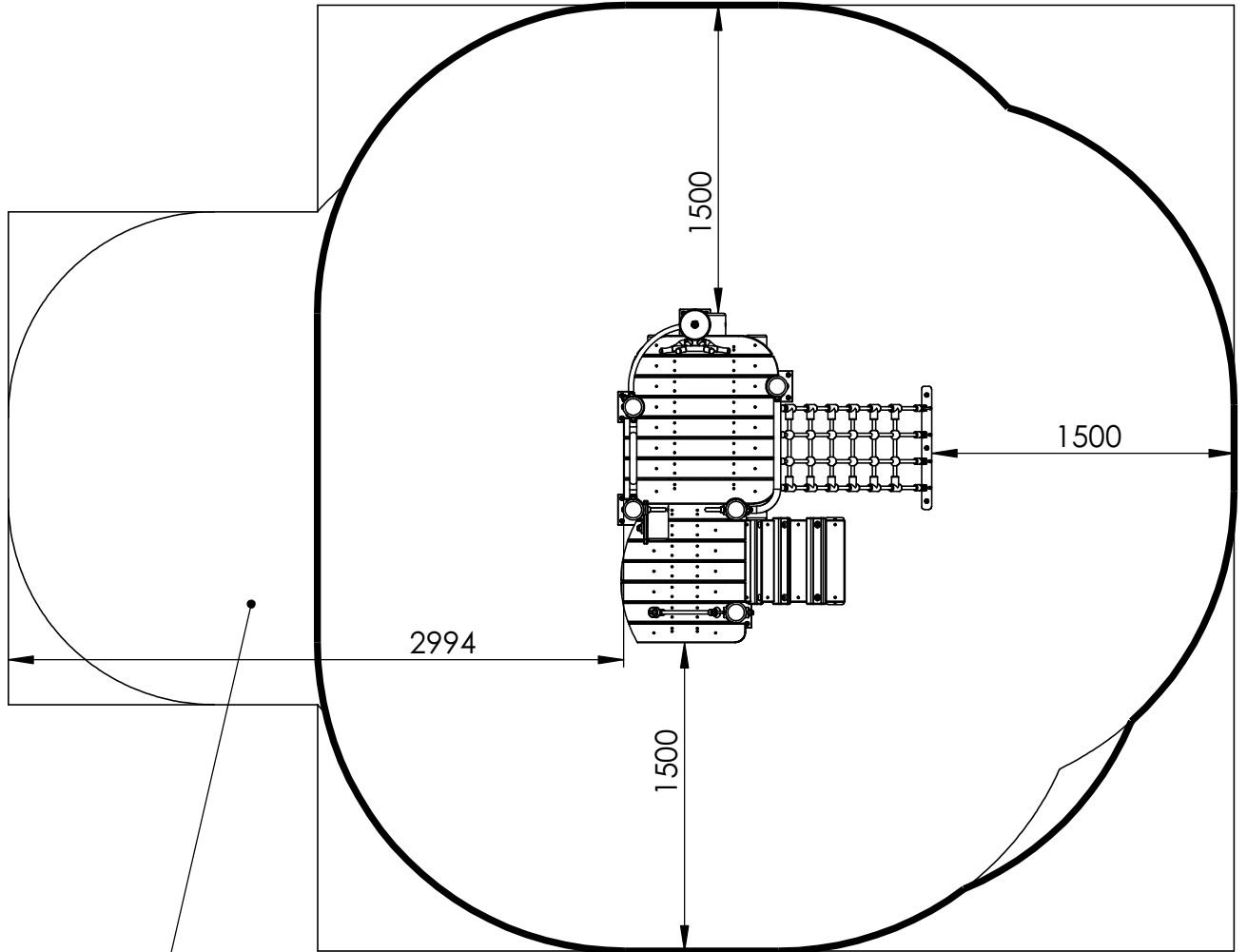

F700B
BASIC

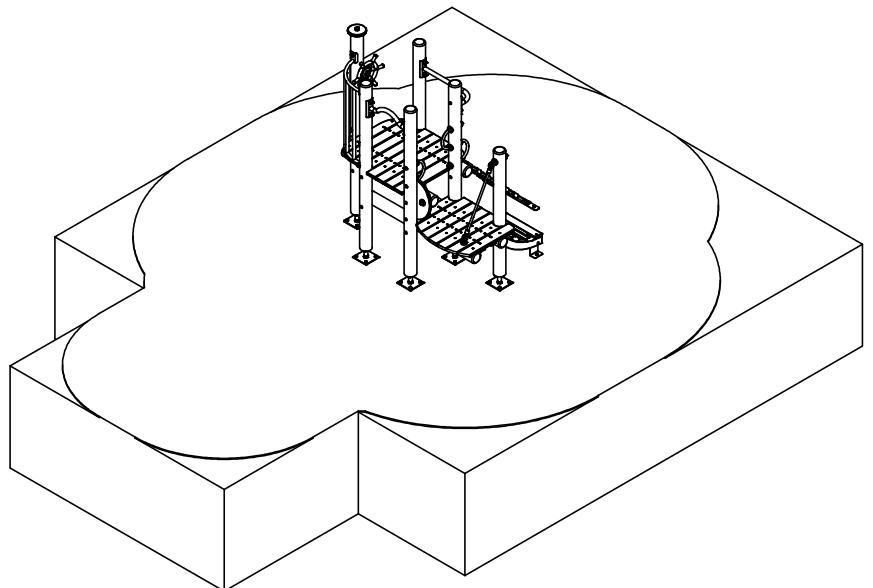

02

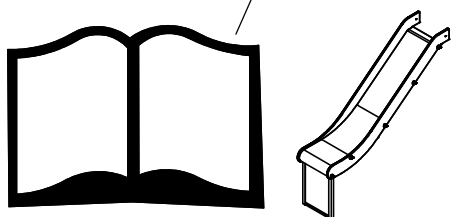
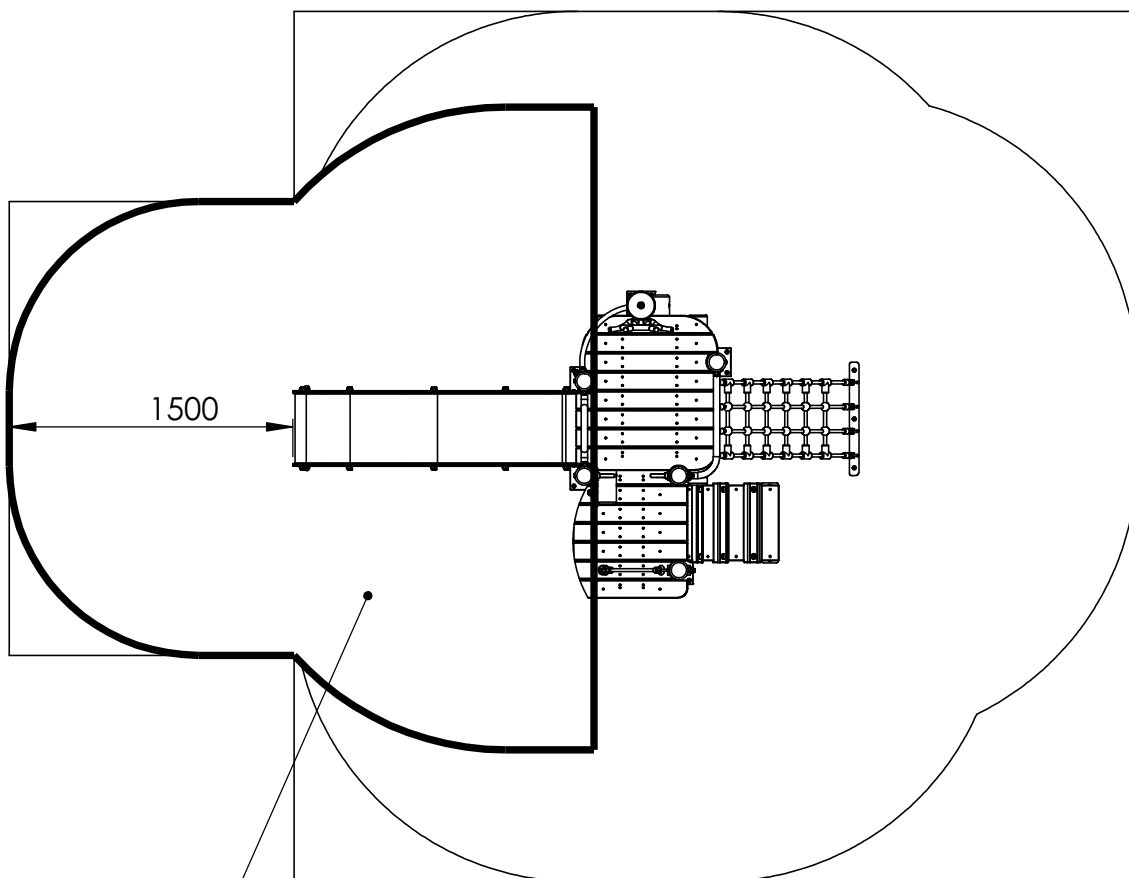

G490B

2B

~~3B~~

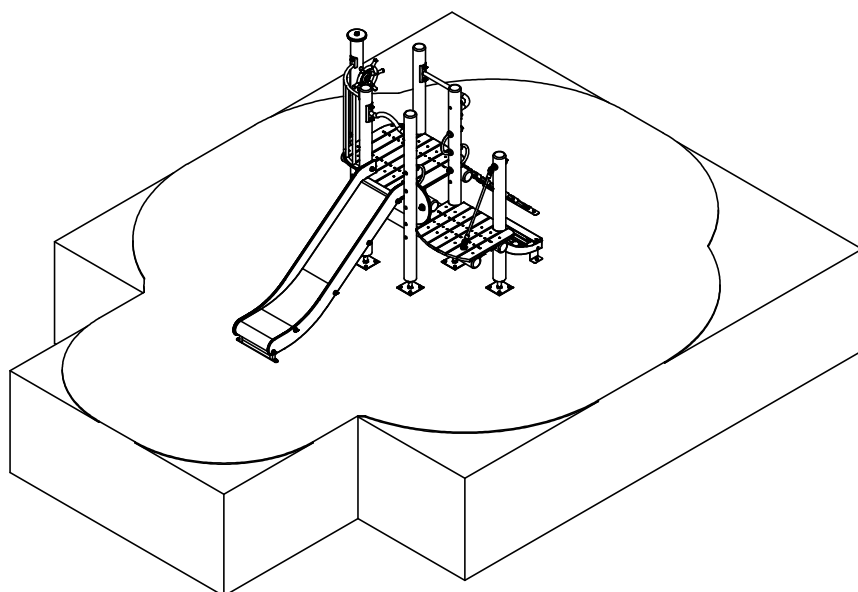

03

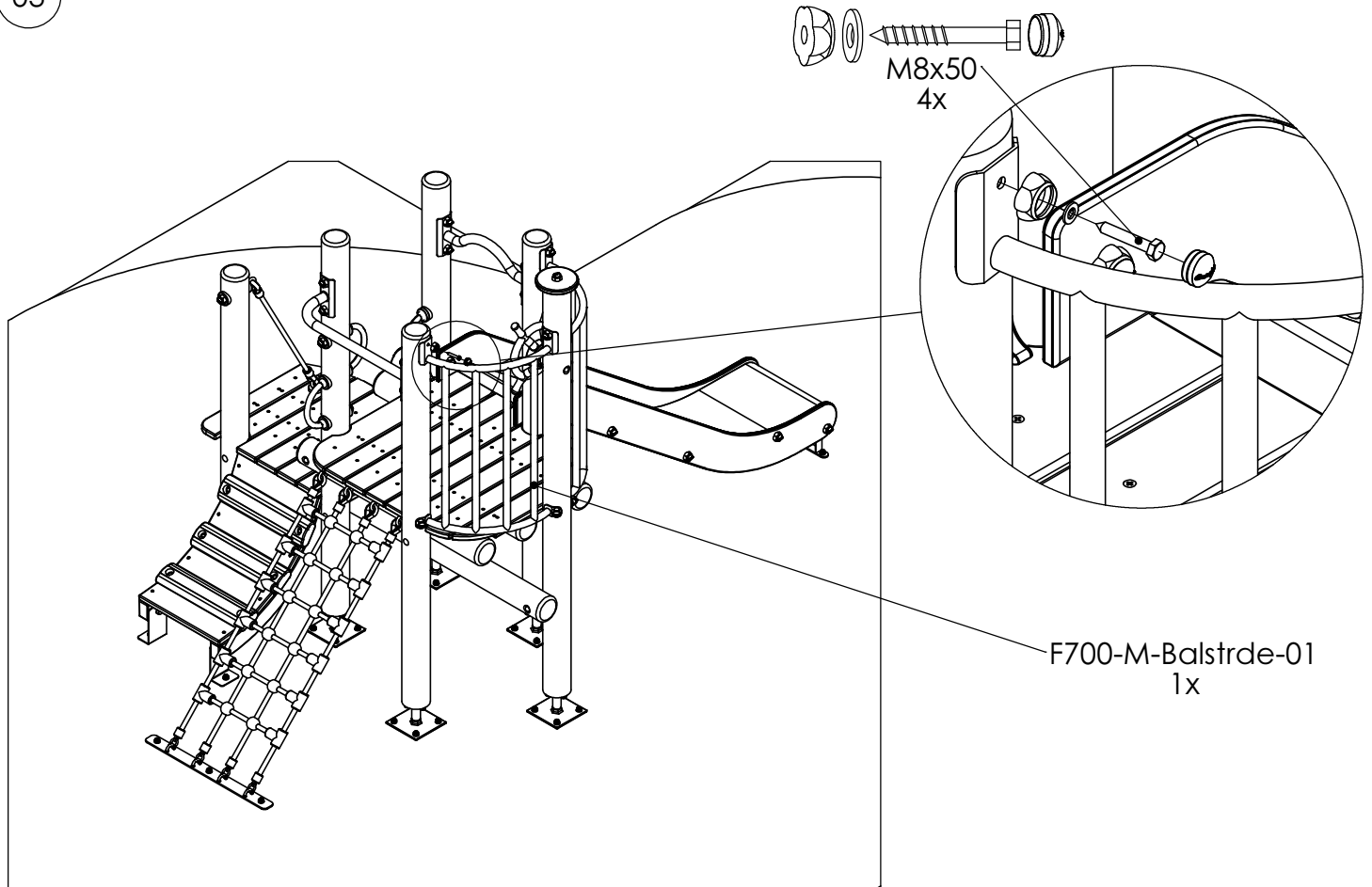

04

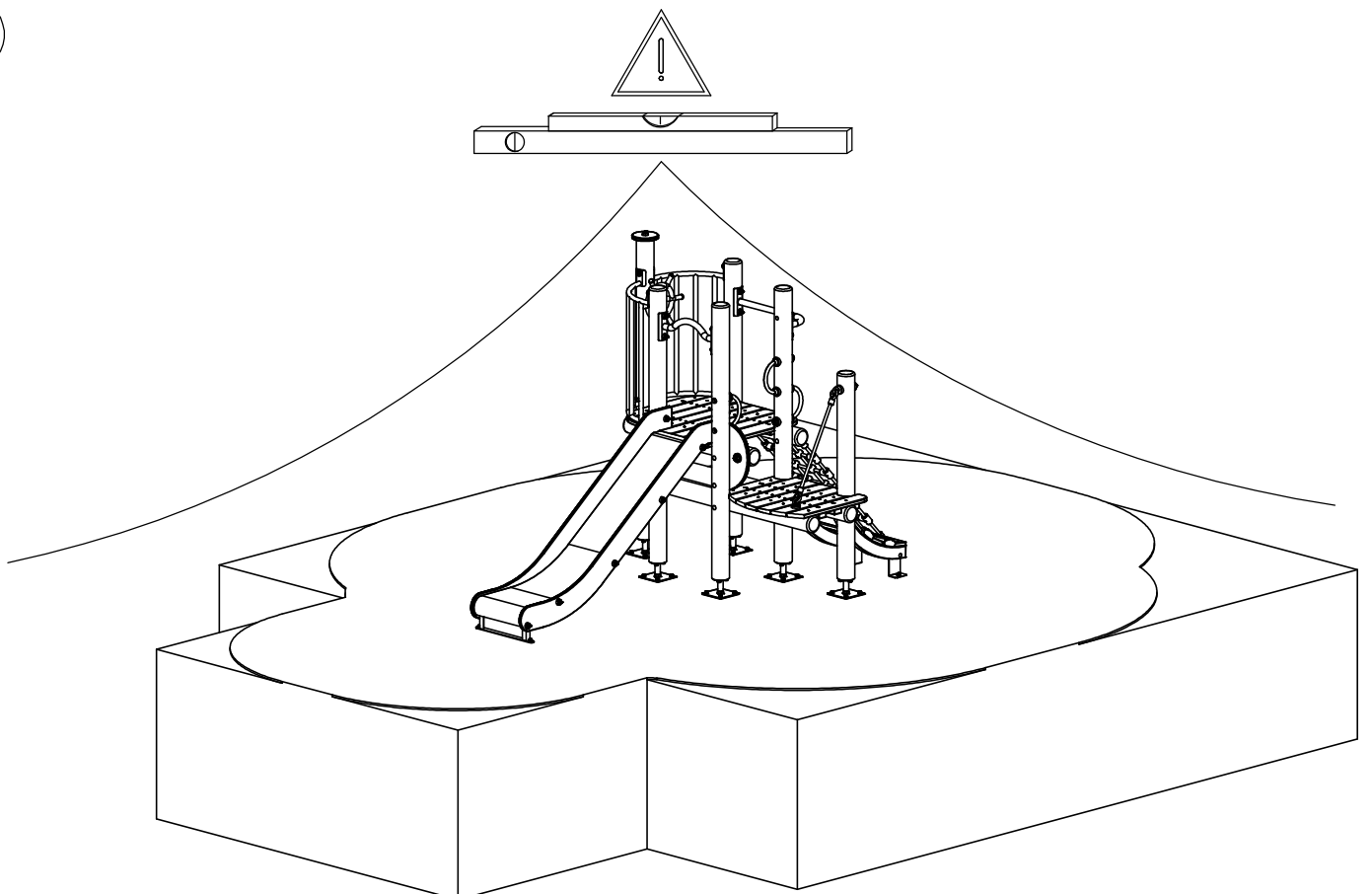

05

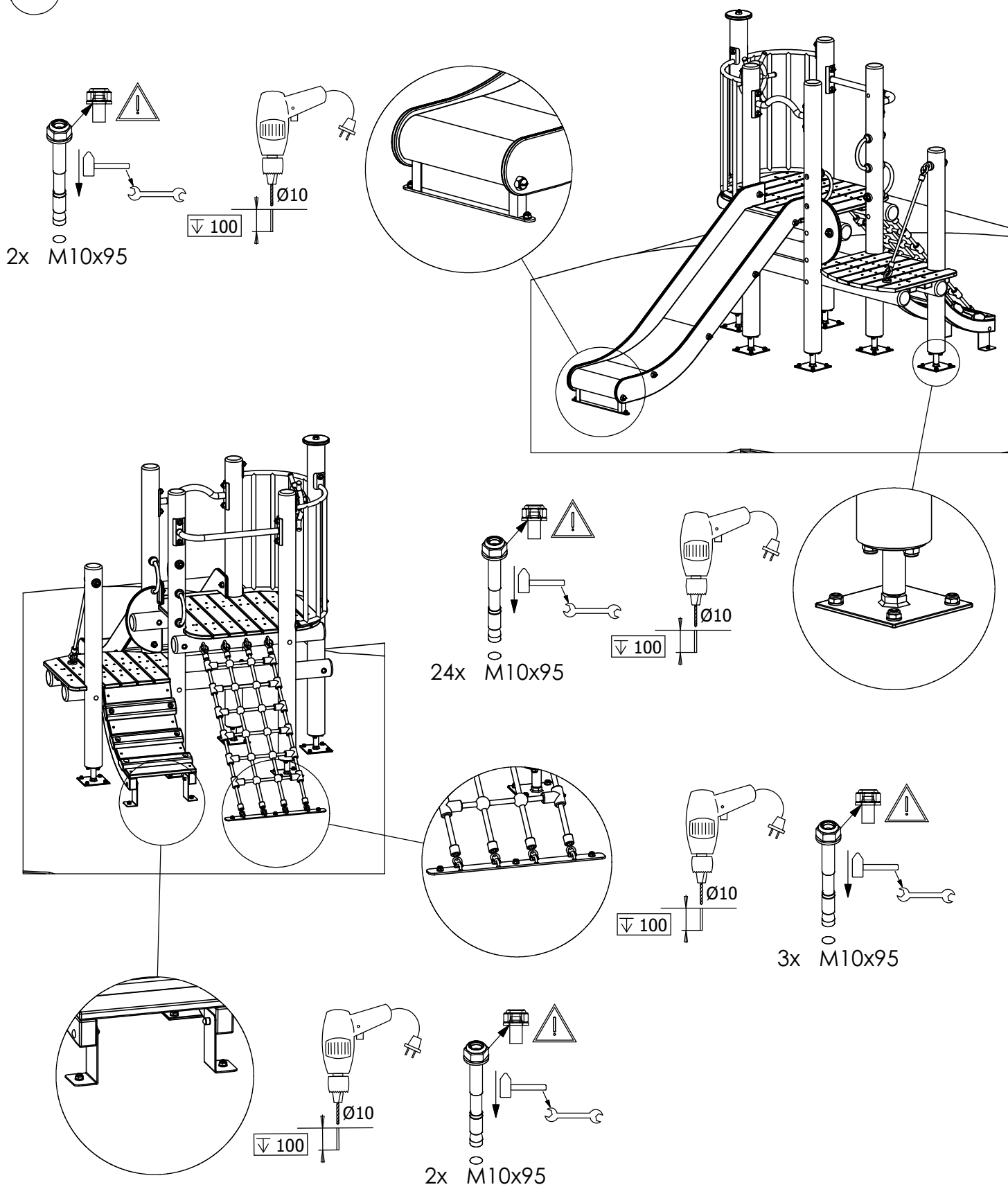

07

Bij droog weer moeten alle bouten en schroeven opnieuw aangespannen worden.
 Par temps sec il faut resserrer régulièrement toute la visserie.
 By dry and warm weather check the tightness of all bolts and screws.
 Bei trockenem Wetter müssen alle Schrauben und Bolzen aufs neue angespannt werden.
 Para el tiempo seco, se necesita cerrar o ajustar los tornillos y tuercas.
 Con tempo asciutto, tutti i bulloni e le viti devono essere avvitati nuovamente.

