

G700A

Vlindertuin
Le jardin des papillons
Butterfly garden
Schmetterlingsgarten
Jardin de mariposas
Giardino delle Farfalla

Montagehandleiding Notice de montage Assembling manual Montageanleitung Instrucciones para el montaje Istruzioni di installazione

Leeftijd
Age group
Age / Alter
Edad / Età
1 - 3

EUROPLAY nv
Eegene 9
B-9200 DENDERMONDE
tel. 32.52.22 66 22
fax.32.52.22 67 22
www.europly.eu

Dat.: 22/04/2021

Rev.: -

Page: 1/5

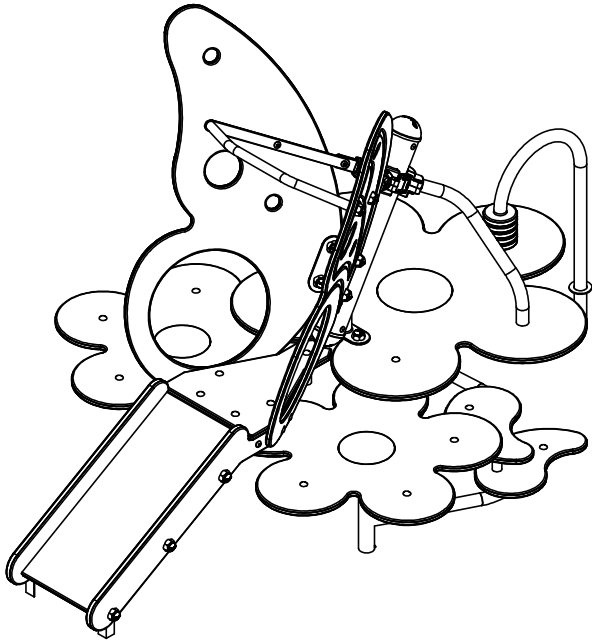

130kg

VALHOOGTE / HAUTEUR DE CHUTE /
FALL HEIGHT / FALLHÖHE/
ALTURA DE CAÍDA / ALTEZZA DI CADUTA

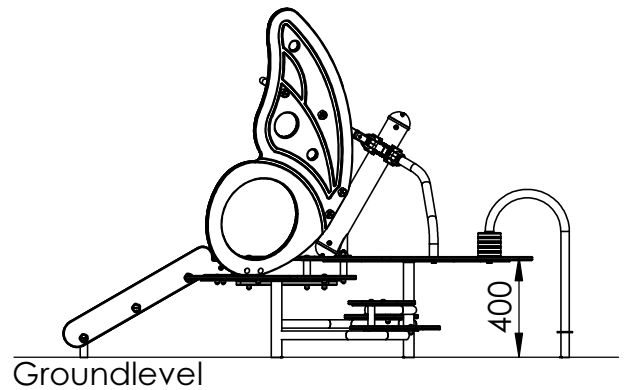

VEILIGHEIDSAFSTAND / ESPACE DE CHUTE / SAFETY AREA /
SICHERHEITSAFSTAND / ZONA DE SEGURIDAD / DISTANZA DI SICUREZZA

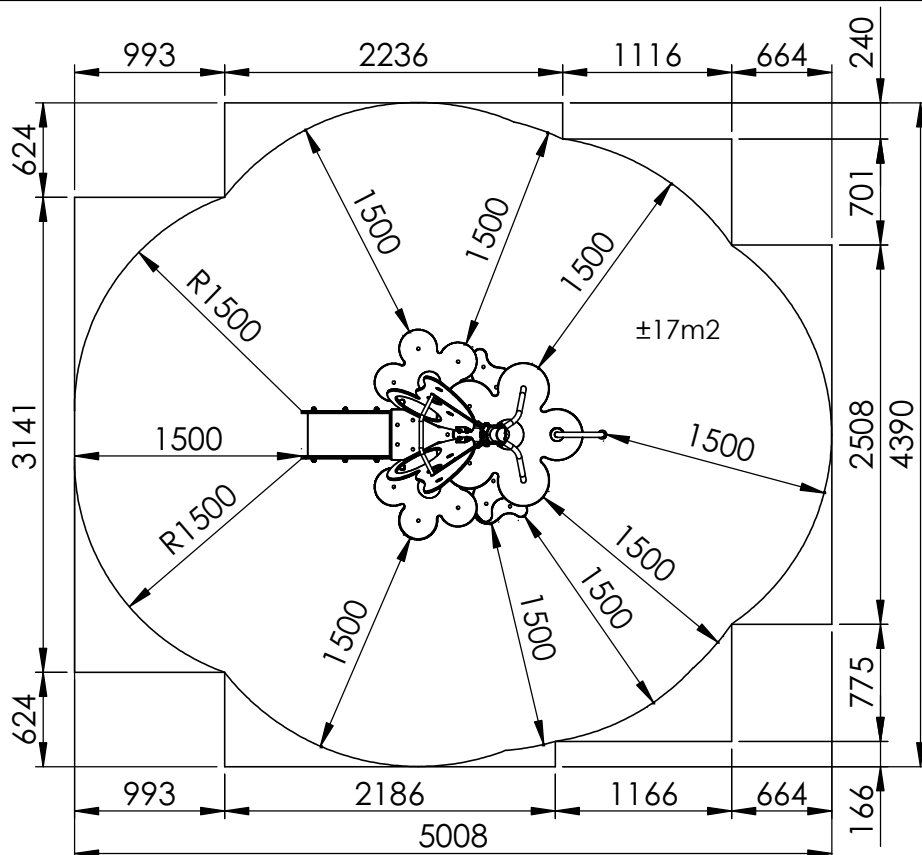



AFMETINGEN
DIMENSIONS
MASSE
DIMENSIONES
DIMENSIONI
L: 2,1m
Br: 1,4m
H:1,4m

±19m²

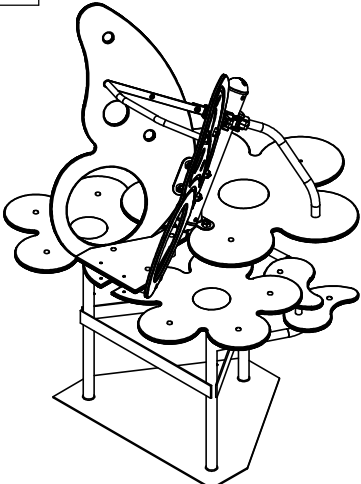
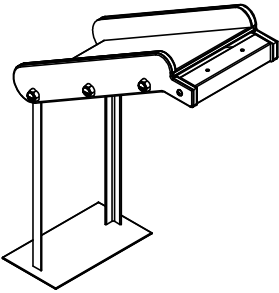
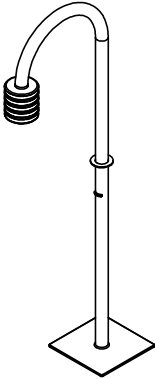
Benodigdheden - Liste des pièces - Materials - Benötigtes - Accesorios - Requisiti

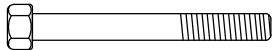
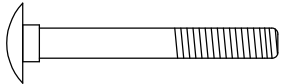
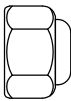
1x G700-As-Vlinder-01	1x G700-As-Loopwand-01	1x G700-As-Glijbuis-01
		
1362x1390x1390 109.39kg	1045x360x844 12.13kg	362x200x1166 5.28kg

1x M10x40	
2x M8x105	
2x M8	
2x M8	

①

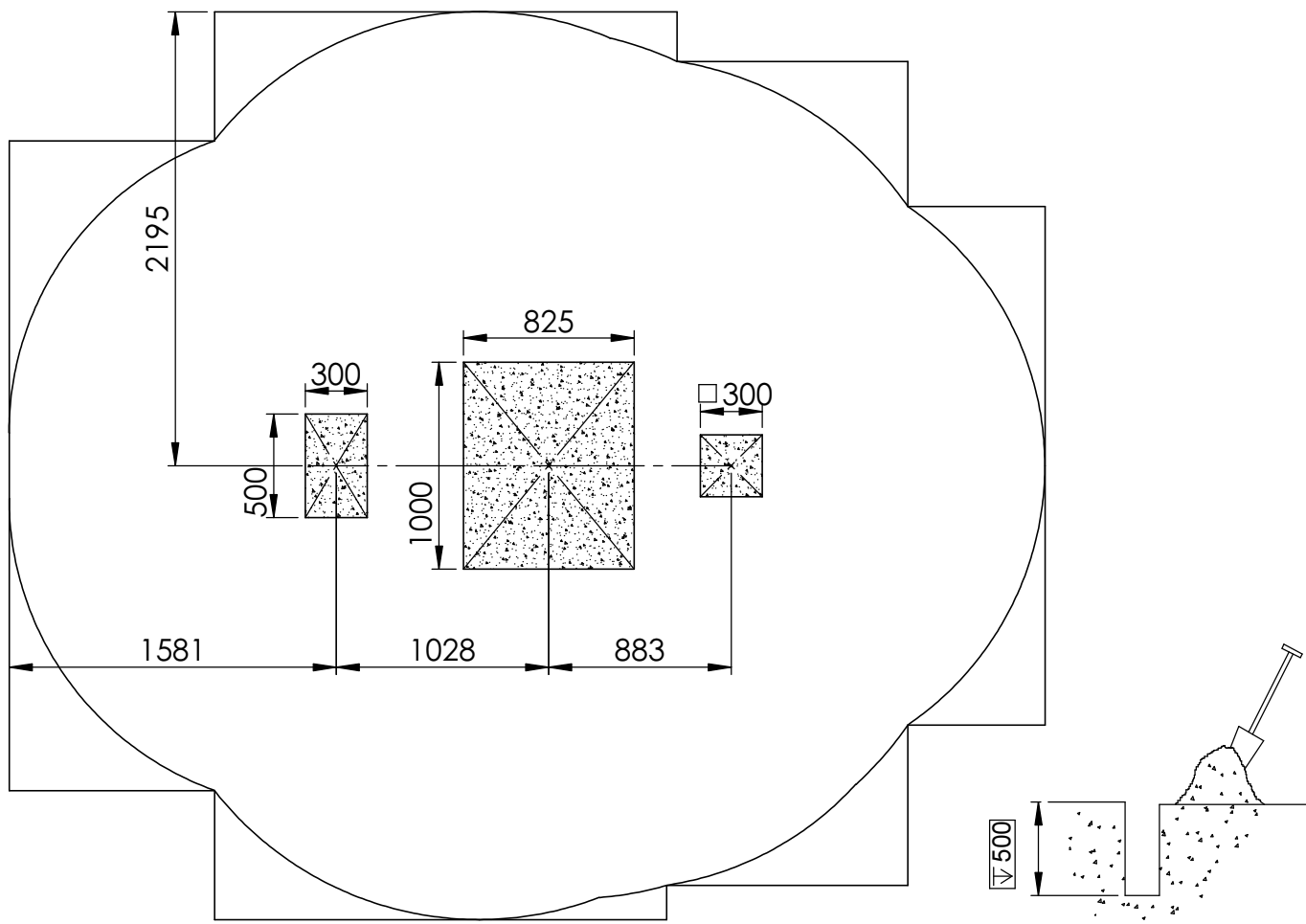

②

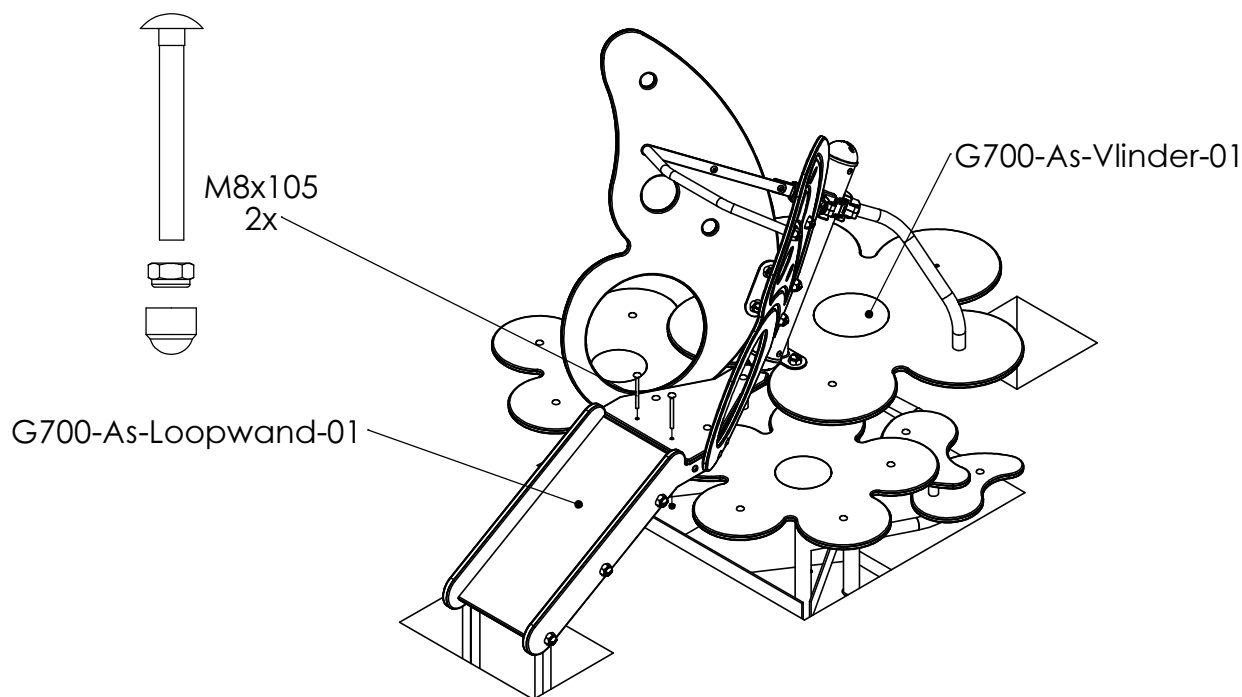

③

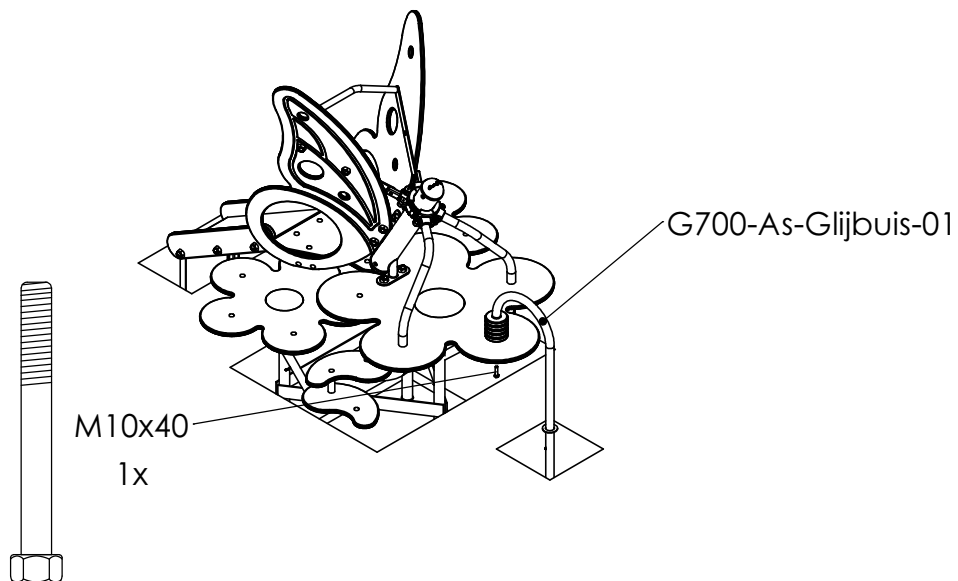

④

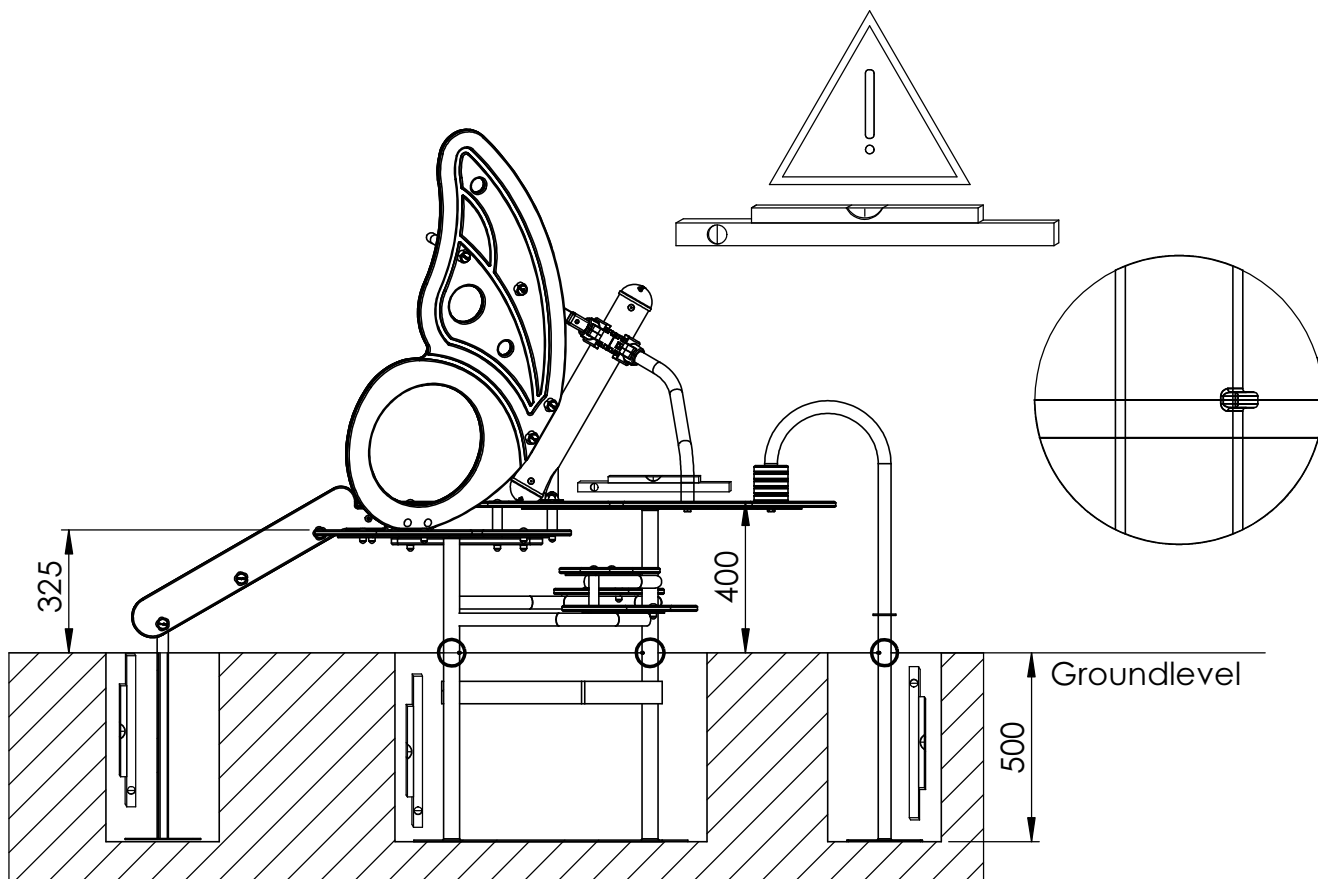

⑤

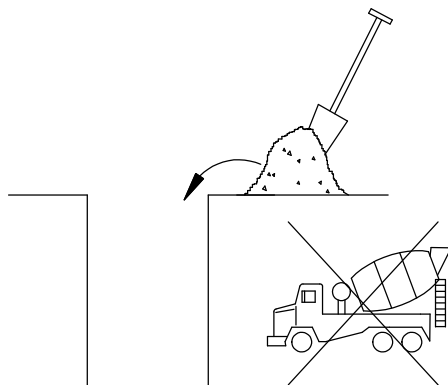

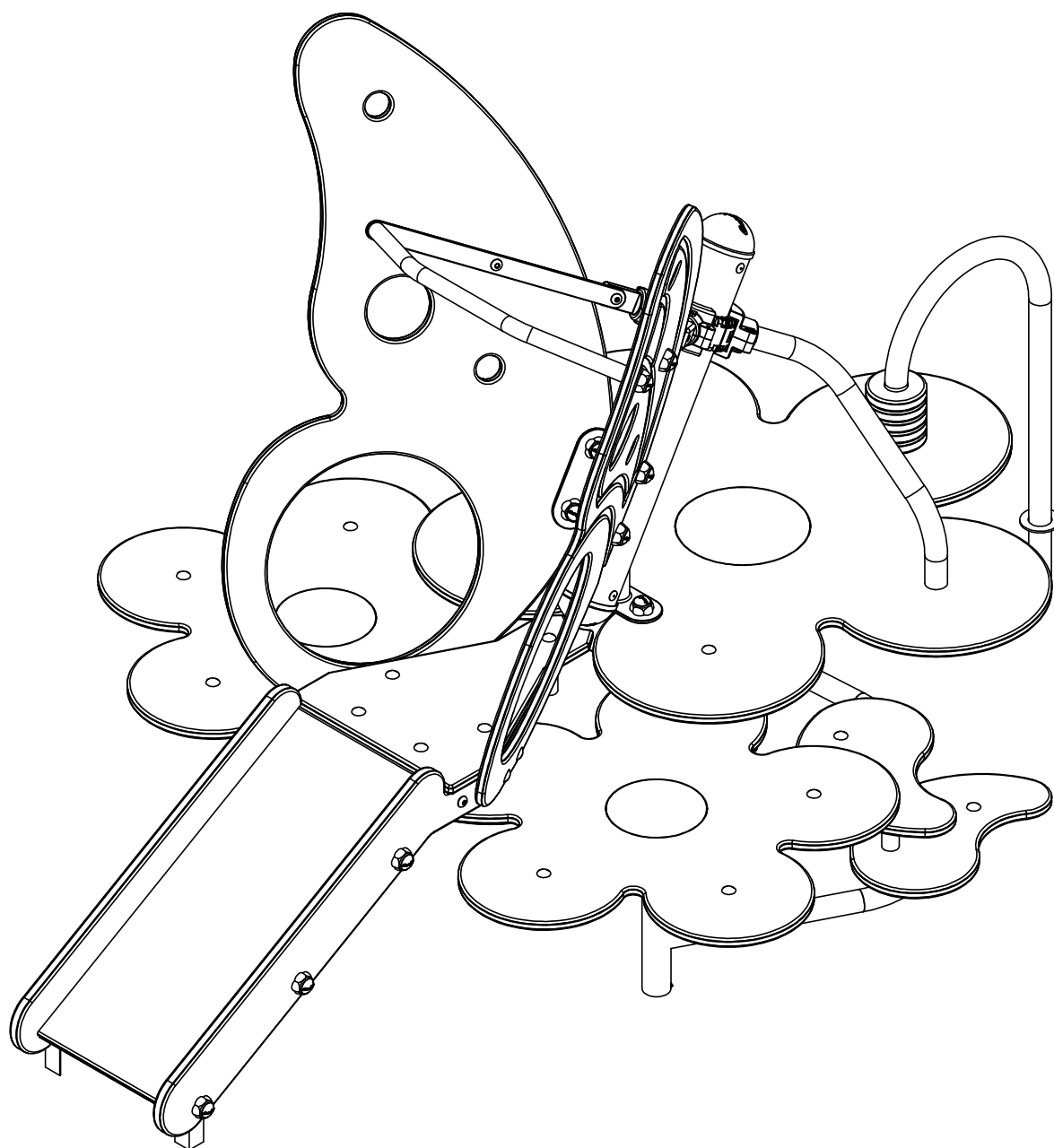

- ⑥ Bij droog weer moeten alle bouten en schroeven opnieuw aangespannen worden.
Par temps sec il faut resserrer régulièrement toute la visserie.
By dry and warm weather check the tightness of all bolts and screws.
Bei trockenem Wetter müssen alle Schrauben und Bolzen aufs neue angespannt werden.
Para el tiempo seco, se necesita cerrar o ajustar los tornillos y tuercas.
Con tempo asciutto, tutti i bulloni e le viti devono essere avvitati nuovamente.