

F0011A

Belle en het beest
La belle et la bête
Die schöne und das biest
Beauty and the beast
La bella y la bestia
La bella e la bestia

Montagehandleiding Notice de montage Assembling manual Montageanleitung Instrucciones para el montaje Istruzioni di installazione

Leeftijd
Age group
Age / Alter
Edad / Età
2 - 6

EUROPLAY nv
Eegene 9
B-9200 DENDERMONDE
tel. 32.52.22 66 22
fax.32.52.22 67 22
www.europlay.eu

Dat.: 16/12/2019

Rev.: -

Page: 1/10

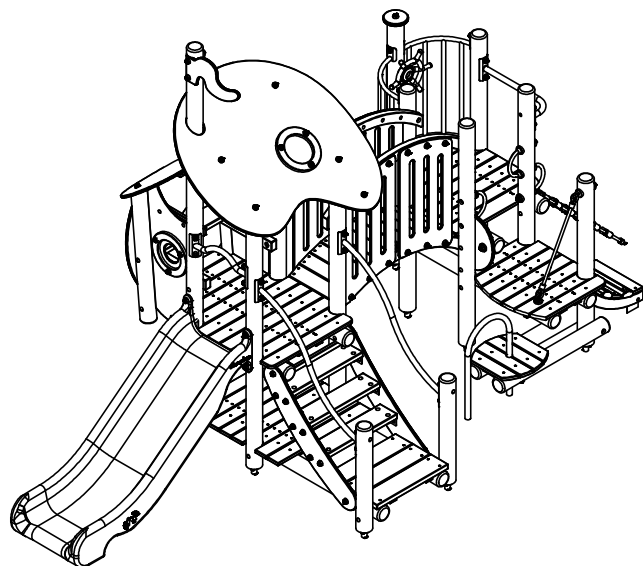

±350kg

VALHOOGTE / HAUTEUR DE CHUTE /
FALL HEIGHT / FALLHÖHE/
ALTURA DE CAÍDA / ALTEZZA DI CADUTA

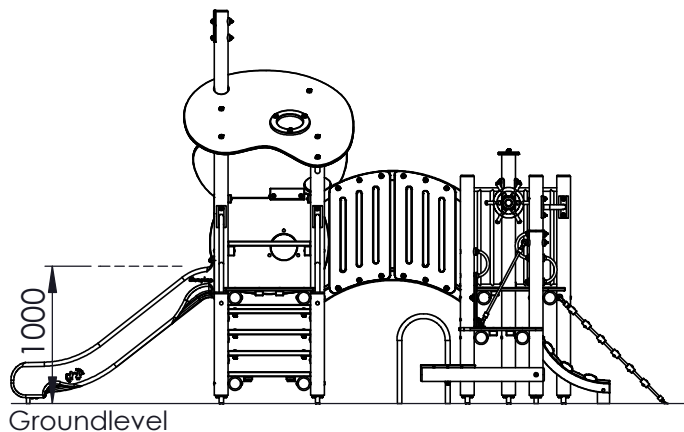

Groundlevel

VEILIGHEIDSAFSTAND / ESPACE DE CHUTE / SAFETY AREA /
SICHERHEITSAFSTAND / ZONA DE SEGURIDAD / DISTANZA DI SICUREZZA

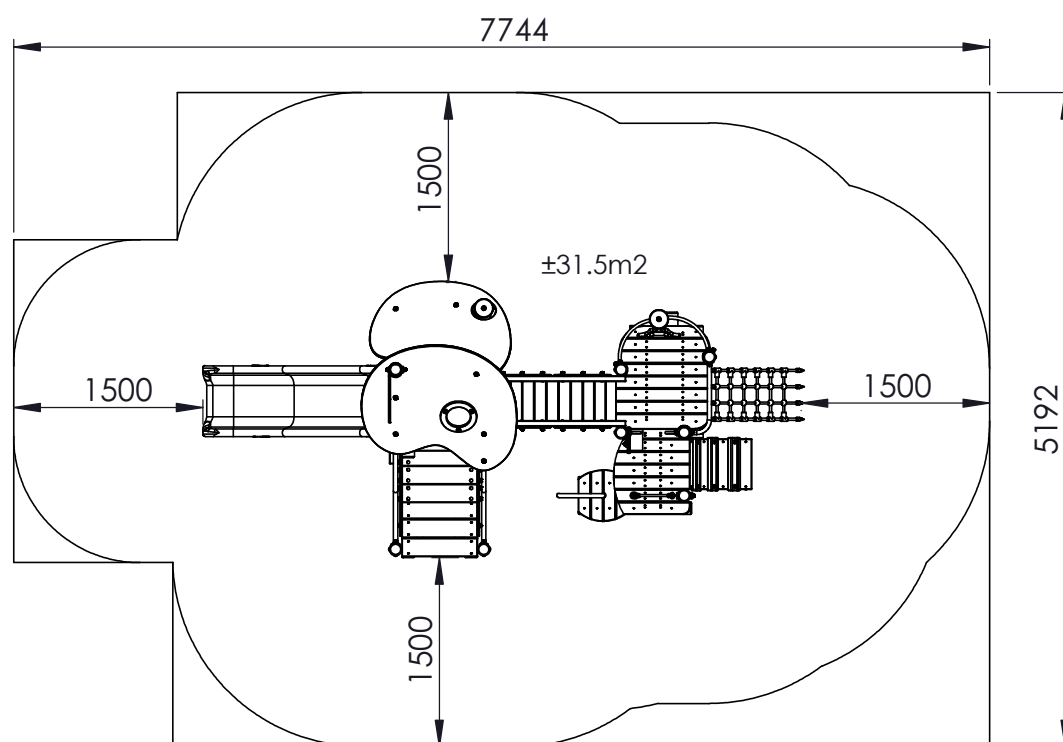

AFMETINGEN
DIMENSIONS
MASSE
DIMENSIONES
DIMENSIONI
L: 4.8m
Br: 2.2m
H: 2.9m

37m²











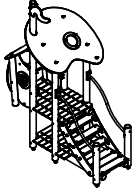
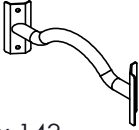

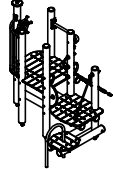
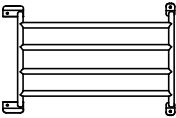
F0011A

Montagehandleiding - Notice de montage
 Assembling manual - Instrucciones para el montaje
 Montageanleitung - Istruzioni di installazione

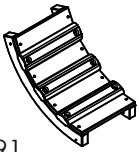
Dat.: 16/12/2019

Page: 2/10

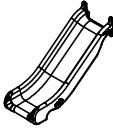
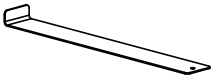
Benodigdheden - Liste des pièces - Materials - Benötigtes - Accesorios - Requisiti

 F100A BASIC		1x F100-M-VeiligB-02  641,1 x 176,9 x 143 1.66kg	4x M8x50 4x M10x50  2x M10x80
 F710A		1x F700-M-Balstrde-01  795,2 x 600 x 313 4.59kg	2x M10  2x M8x55 
 F010		1x F300-As-Klimboog-01  724 x 420 x 191 6.01kg	2x M8  2x M8 
 G310A		2x Lb-M-Anker-01  685 x 90 x 40 1.52kg	8x White  

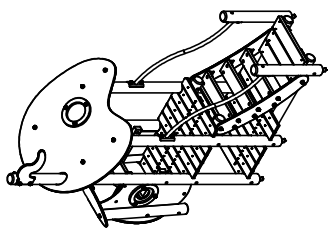
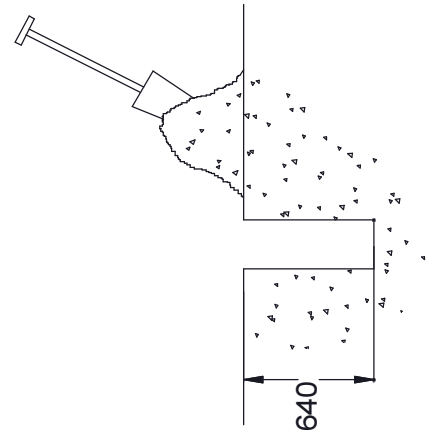
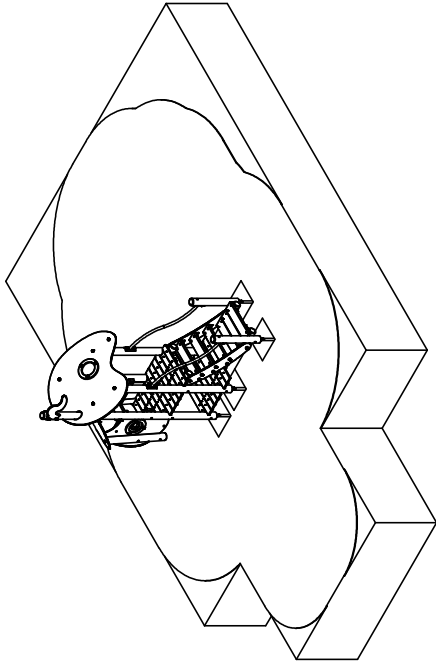

F100A
BASIC

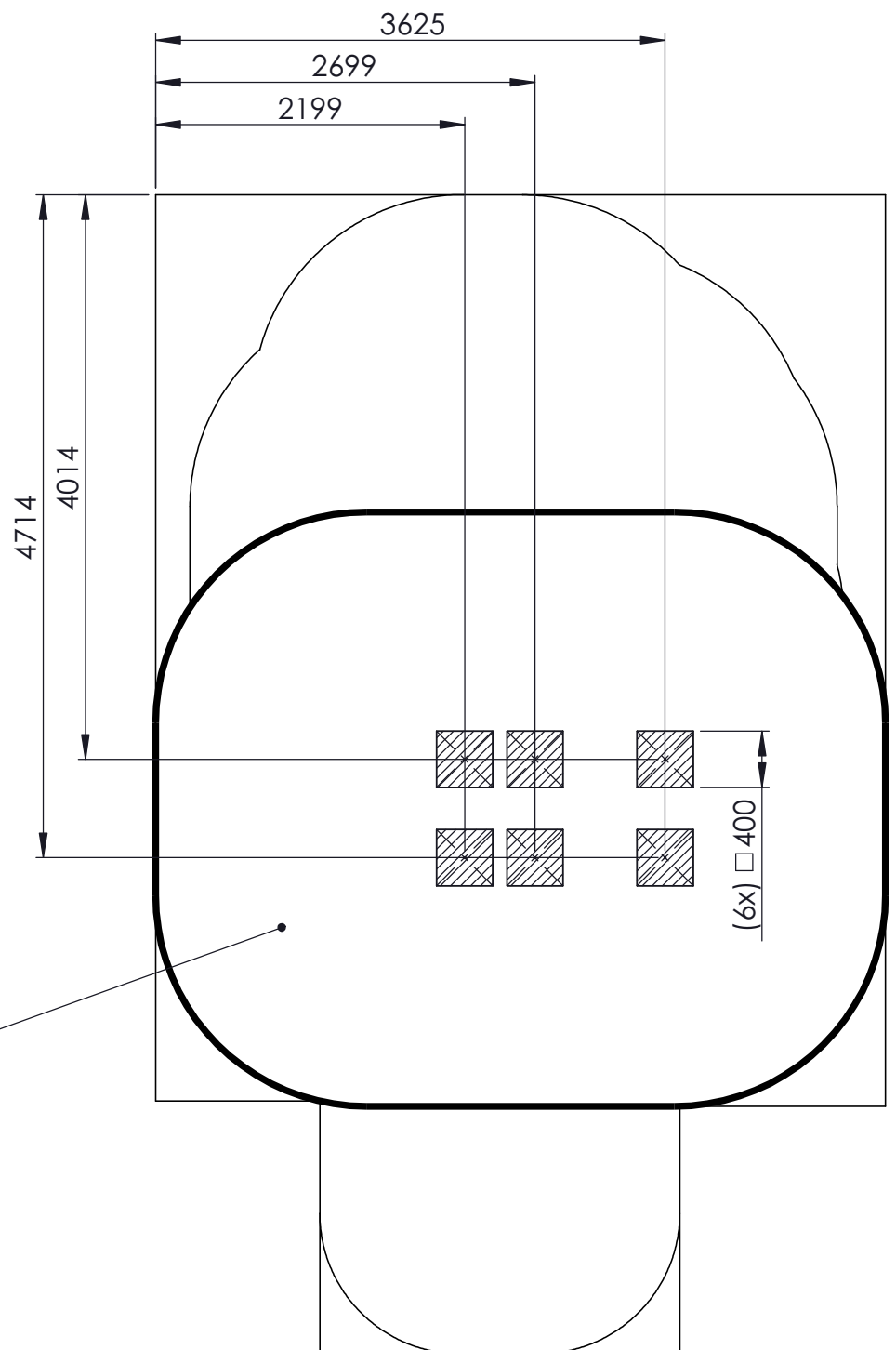

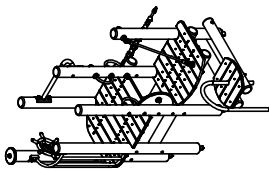
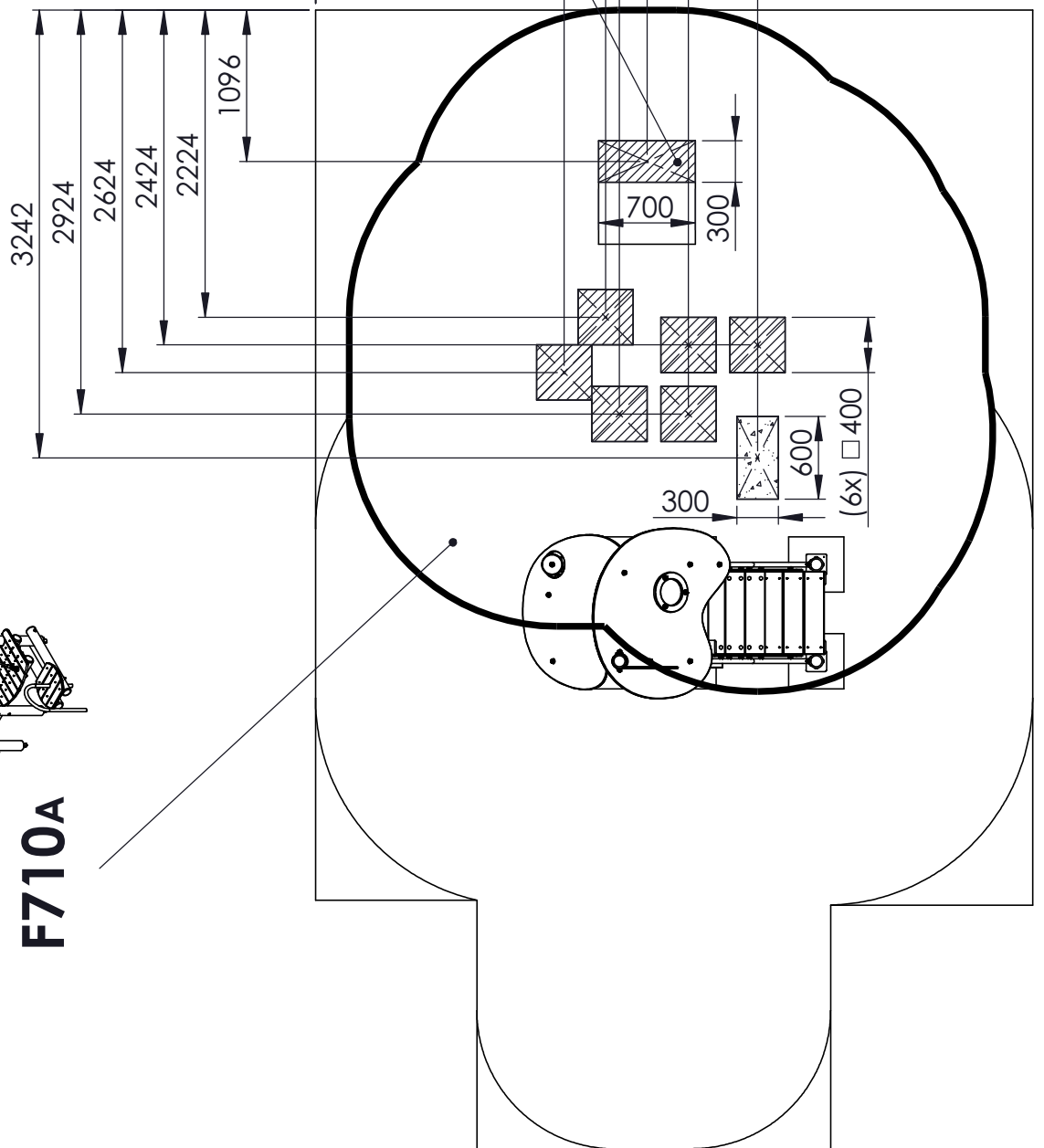
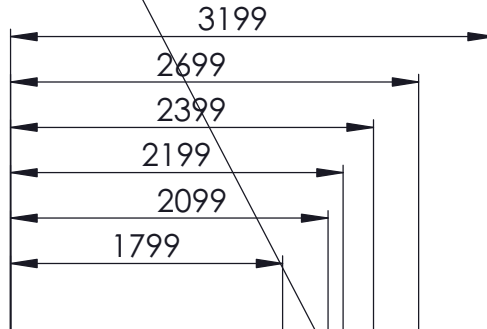
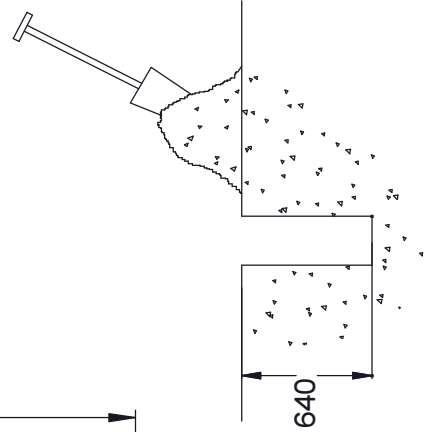
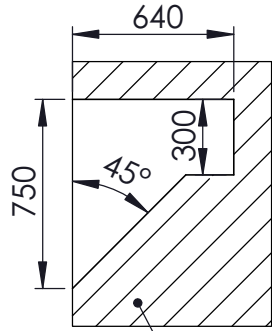
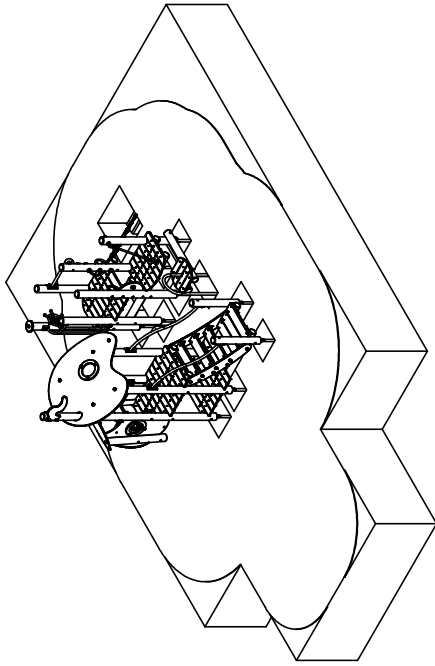

F710A

03

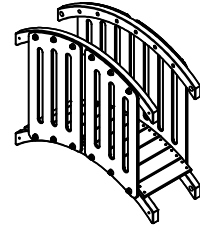
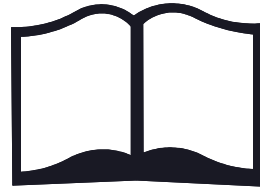

F010

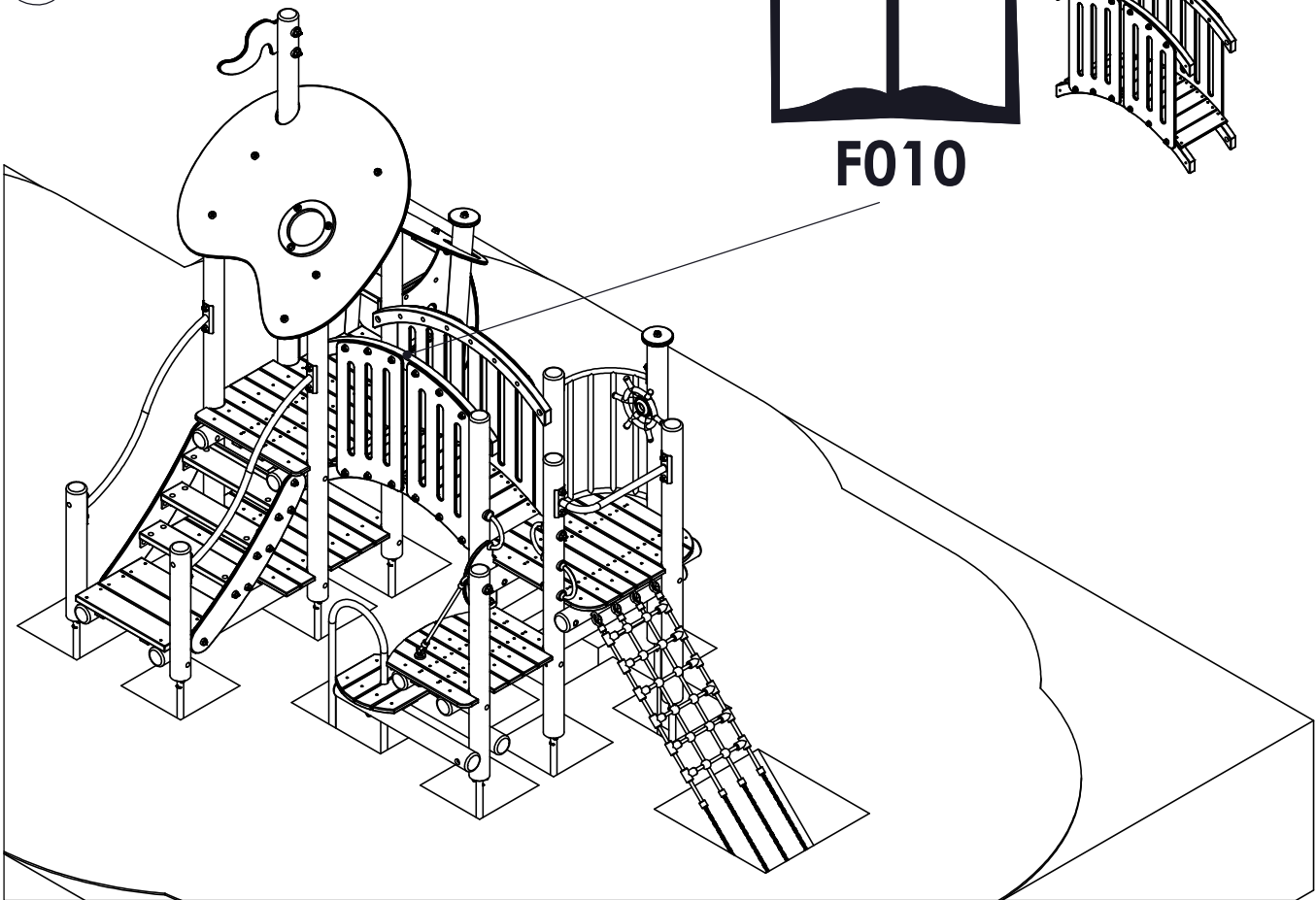

04

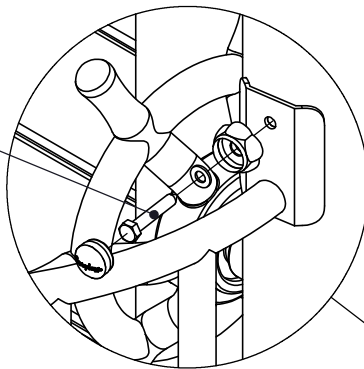
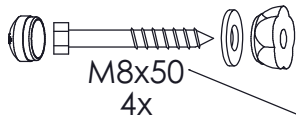

F700-M-Balstrde-01
1x

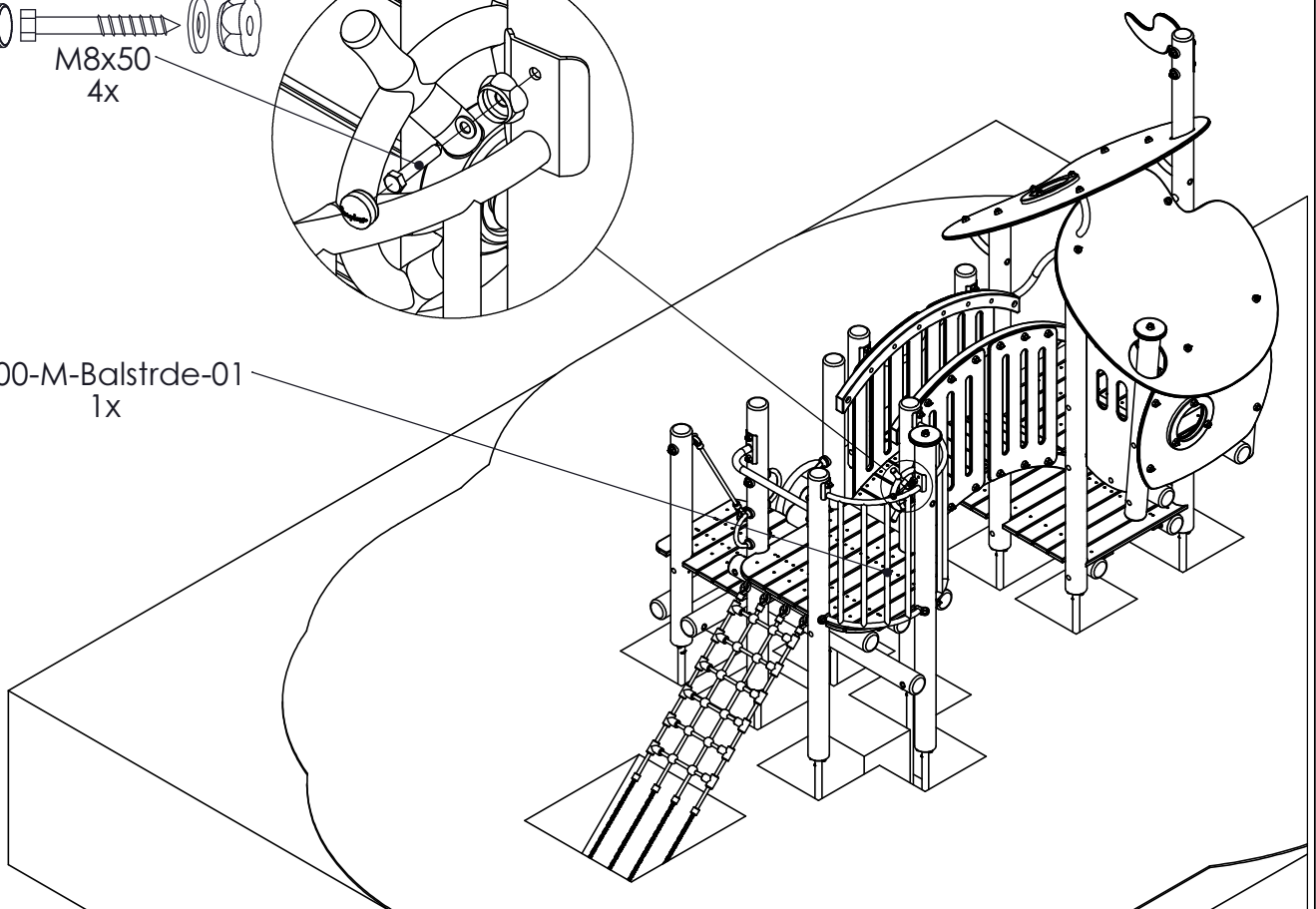

05

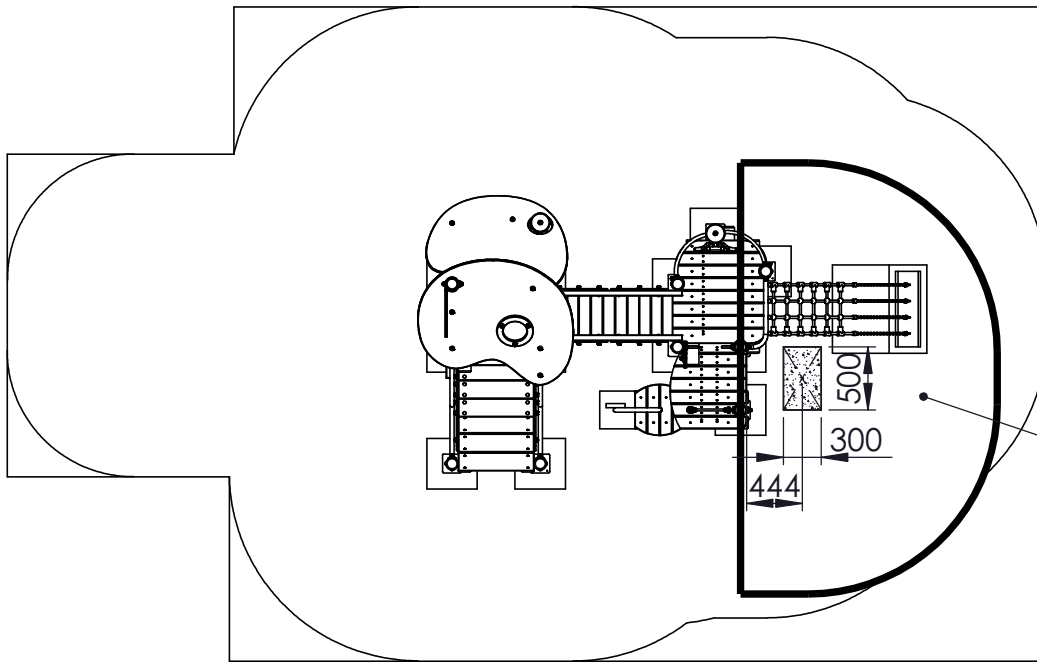

640

F300-As-Klimboog-01

F300-As-Klimboog-01

1x

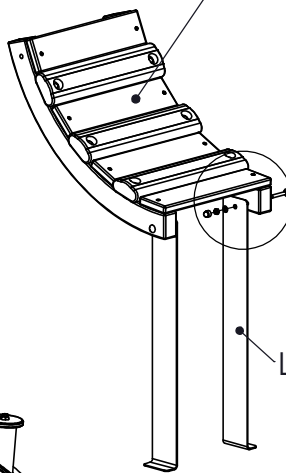
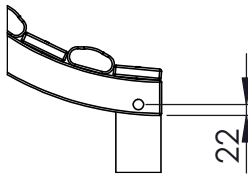

Lb-M-Anker-01
2x

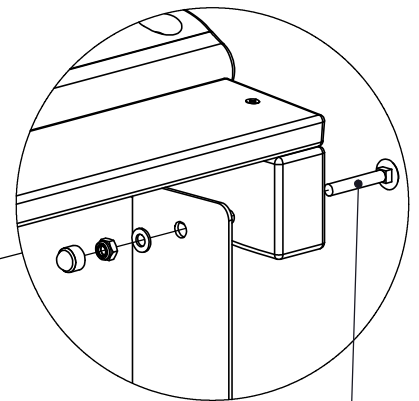

M8x55
2x

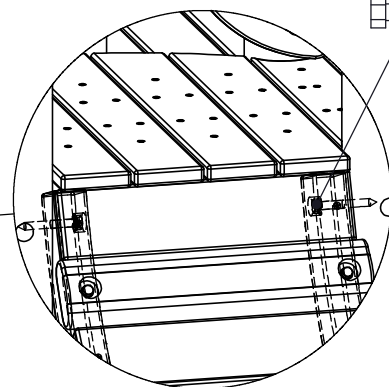
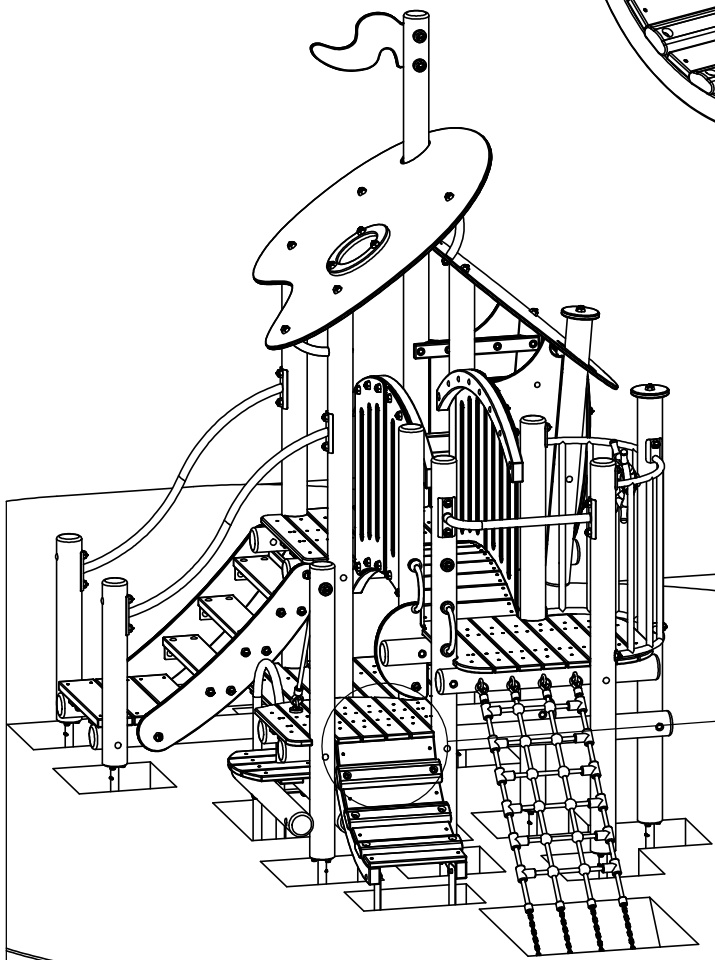

M10x80
2x



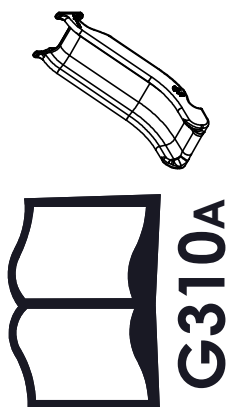
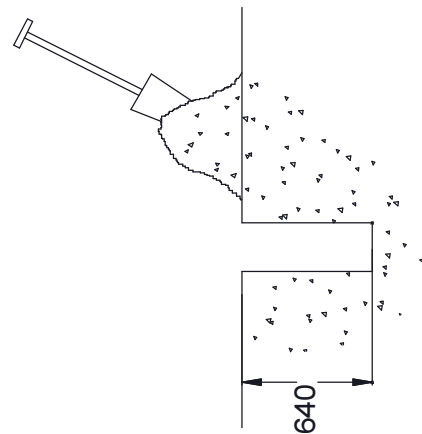
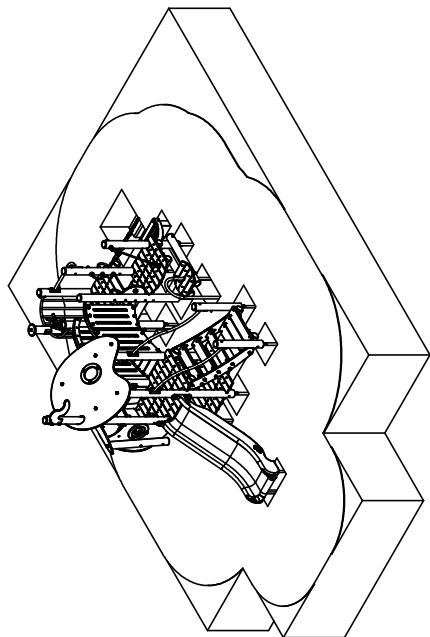

G310A

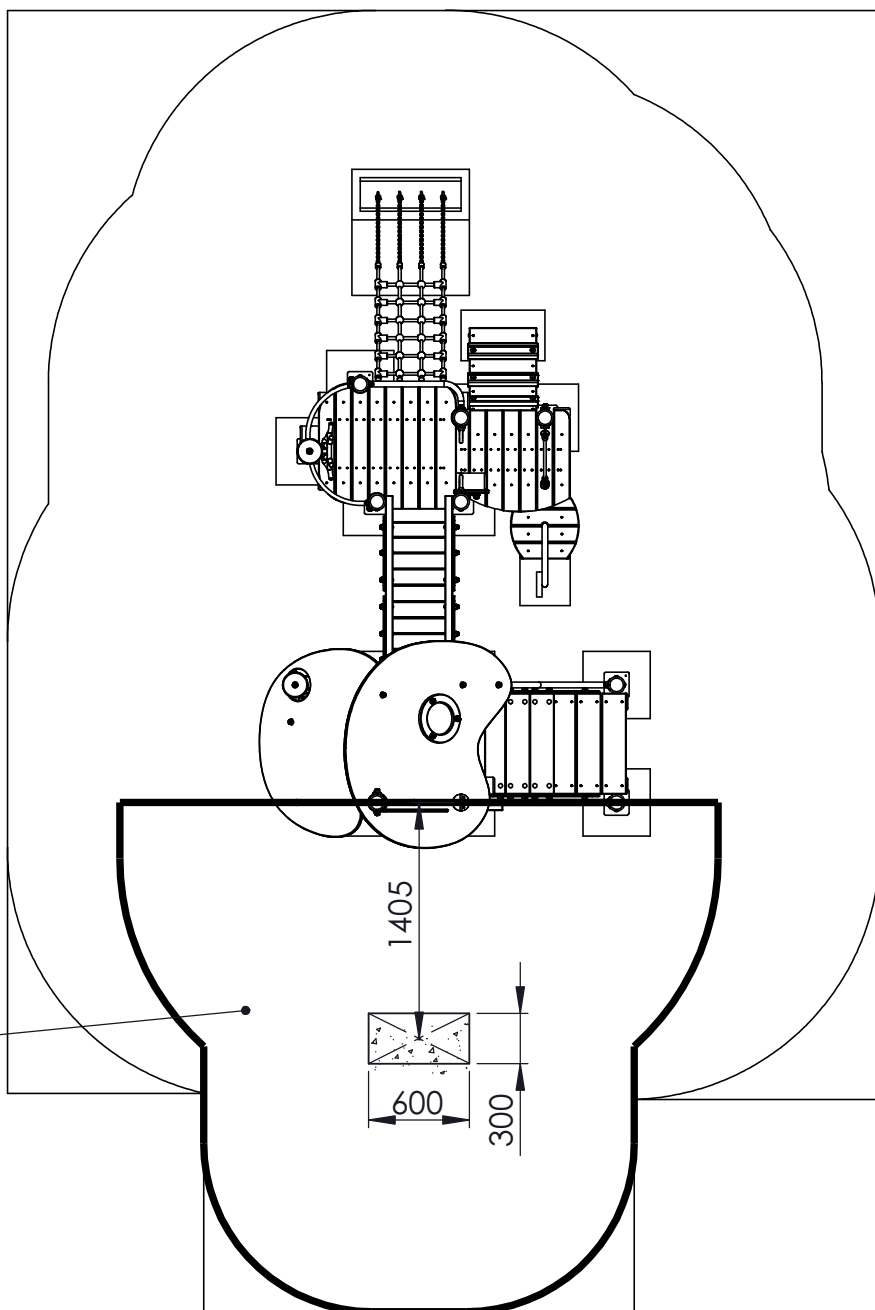

07

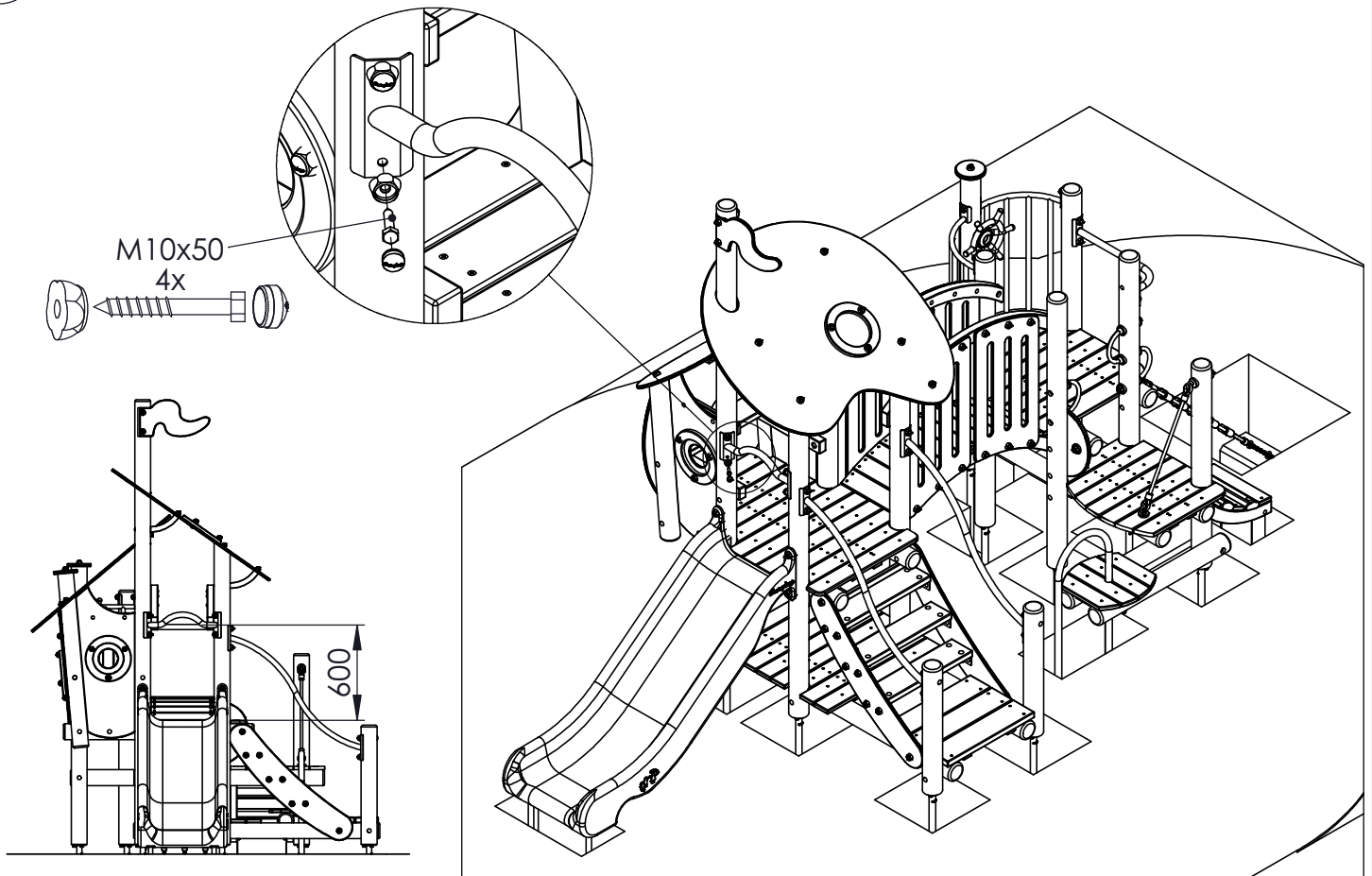

08

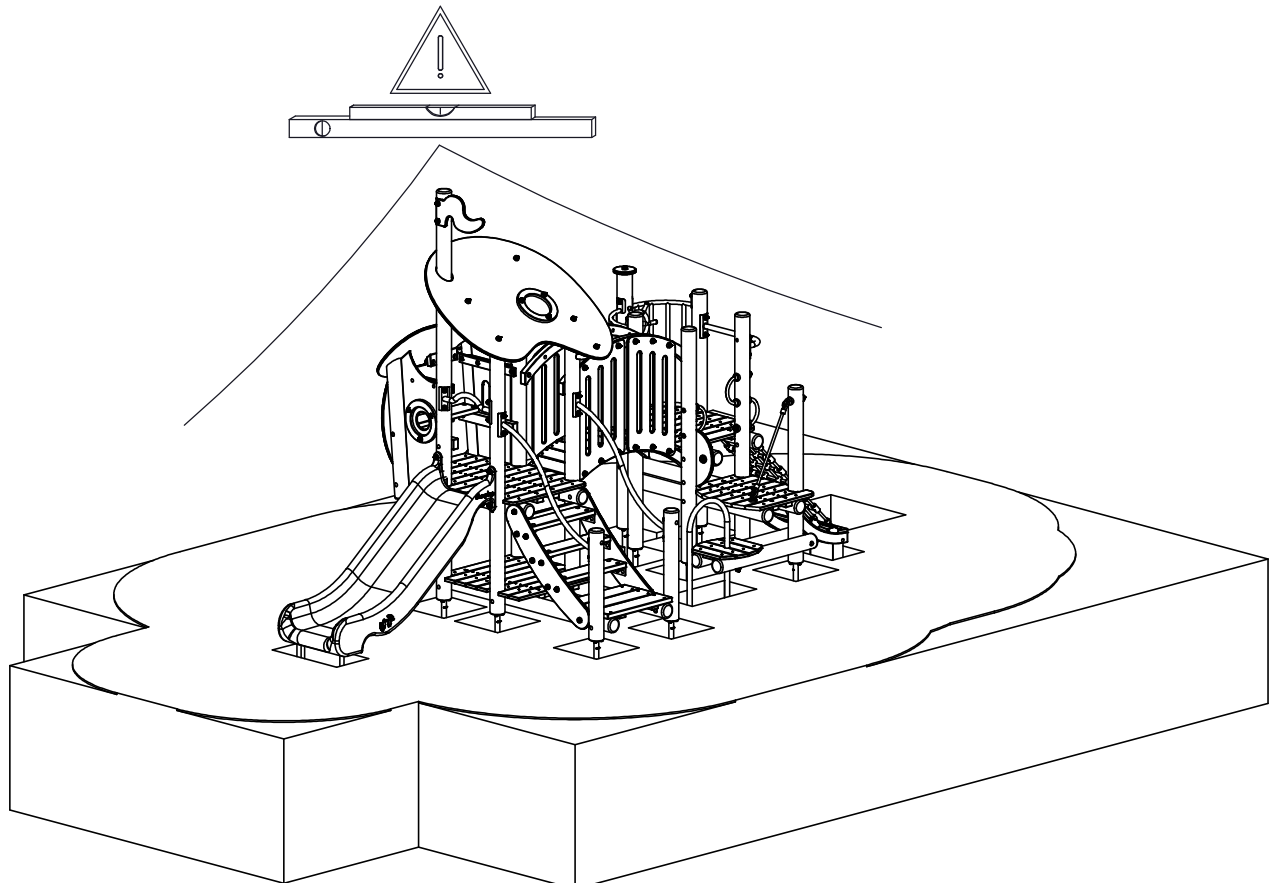

09

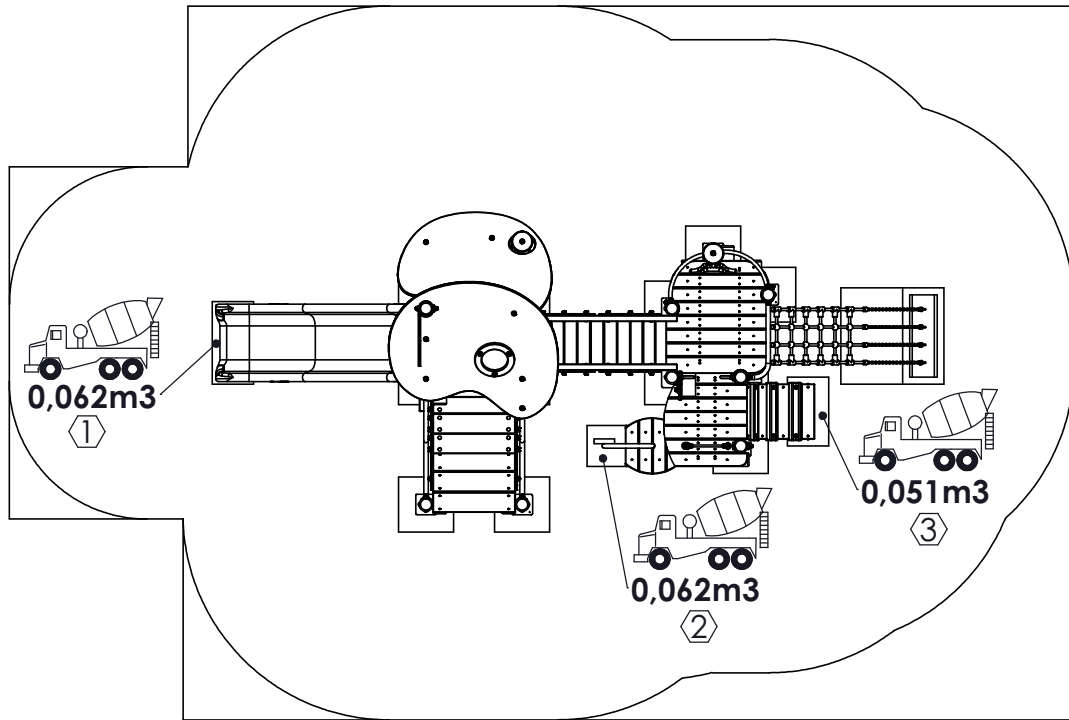

①

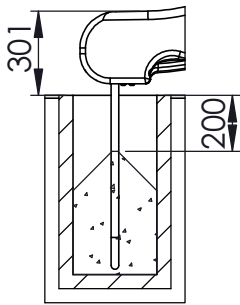

0,062m³

②

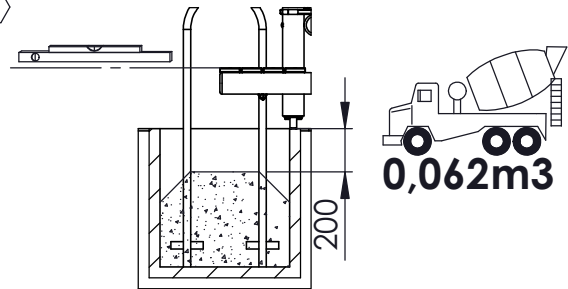

0,062m³

③

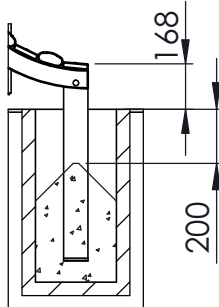

0,051m³

10

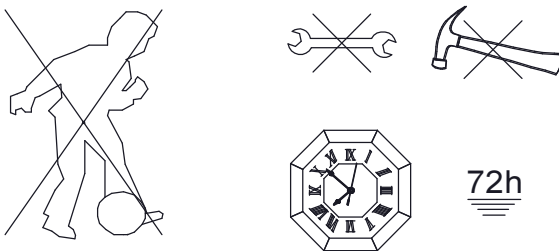

72h

11

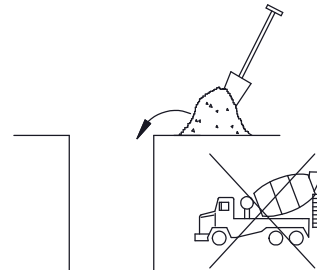

12

Bij droog weer moeten alle bouten en schroeven opnieuw aangespannen worden.
 Par temps sec il faut resserrer régulièrement toute la visserie.
 By dry and warm weather check the tightness of all bolts and screws.
 Bei trockenem Wetter müssen alle Schrauben und Bolzen aufs neue angespannt werden.
 Para el tiempo seco, se necesita cerrar o ajustar los tornillos y tuercas.
 Con tempo asciutto, tutti i bulloni e le viti devono essere avvitati nuovamente.

